

VF66R

PWM Sine Wave Converter

Operating Manual



Table of Contents

Preface.....	4
Be Sure To Read This Before Use	5
Safety Notice.....	5
Chapter 1 Checking and Inspecting Package	8
1.1. Checking Package and Inspection on Purchase.....	8
Chapter 2 Product Overview	10
2.1. Features.....	10
2.2. Configuration.....	10
Chapter 3 How to Install and Connect Converter	12
3.1. Installation Environment and How to Install.....	12
3.1.1. Installation Environment	12
3.1.2. How to Install Converter	12
3.2. How to Open and Close Front Cover.....	14
3.2.1. How to Open Front Cover	14
3.2.2. How to Close Front Cover	17
3.3. How to Connect Converter	19
3.3.1. How to Connect Converter Terminals	19
3.4. Terminal Specifications.....	21
3.5. Notes for Wiring and Electrical Wire Size.....	24
3.5.1. Notes for Wiring.....	24
3.5.2. Electrical Wire Size of Input/Output Device and Main Circuit Wires.....	25
3.5.3. Electrical Wire Size of Control Board	26
3.6. AC Filter.....	27
3.6.1. AC Reactor.....	27
3.6.2. AC Filter Capacitor	28
Chapter 4 Basic Operating Procedures for Converter	29
4.1. Checks before Starting Operation.....	29
4.1.1. About the Control Mode	29
4.1.2. Minimum Parameter Settings	29
4.1.3. Replacing Control Board <VFC66R-Z> with Spare	29
4.2. Basic Operating Procedures from Console.....	30
4.2.1. Explanation of Display and Operation Keys on Console	30
4.2.2. What Are Displayed at Power-on	36
4.2.3. Changing Parameter Settings.....	37
4.2.4. Checking Operating State	40
4.2.5. List of Monitor Items	41
4.3. Operations on Console.....	45

4.4.	Start and Stop through External Contact.....	46
Chapter 5	Explanation of Parameters.....	49
5.1.	List of Parameter Areas.....	49
5.2.	List of Parameters.....	50
5.3.	Detailed Explanation of Each Parameter.....	55
5.3.1.	Basic Setting Area.....	55
5.3.2.	Area A (filter constant setting area).....	57
5.3.3.	Area b (operation command related setting area).....	58
5.3.4.	Area c (multifunction input/output related setting area).....	61
5.3.5.	Area d (converter operation setting area).....	66
5.3.6.	Area E (control gain setting area).....	68
5.3.7.	Area F (protection function/traceback setting area).....	71
5.3.8.	Area G (special adjustment area).....	75
5.3.9.	Area J (setting area for digital communication options).....	75
5.3.10.	Area L (analog input/output setting area).....	77
5.3.11.	Area n (converter mode/model display area).....	79
5.3.12.	Area o (special adjustment area).....	80
5.3.13.	Area P (special adjustment area).....	80
5.3.14.	Area S (converter mode selection and analog input/output adjustment area).....	81
5.4.	Operation Using S Area Parameters.....	83
5.4.1.	How to Clear Protections.....	83
5.4.2.	Data Transfer from/to External Console Option.....	85
5.4.3.	DC Voltage Detection Gain Adjustment.....	94
5.4.4.	Analog Input (2) and (3) Gain and Offset Adjustment.....	97
5.4.5.	Analog Output (2) and (3) Gain and Offset Adjustment.....	102
Chapter 6	Troubleshooting.....	108
6.1.	Protection Messages and Actions.....	108
6.1.1.	Displays and Behaviors in Protection Display Mode.....	108
6.1.2.	List of Protection Messages.....	109
6.1.3.	How to Handle Protection Messages.....	114
6.2.	How to Check Data in Protection Display Mode.....	122
6.2.1.	How to Display Protection Operation Data.....	122
6.2.2.	List of Data of Protection Operation and Protection History Display.....	123
6.3.	How to Reset Protection Display Mode.....	124
6.4.	How to Check Protection History.....	125
Chapter 7	Maintenance and Inspection.....	127
7.1.	Periodic Inspection.....	127
7.2.	Main Circuit Capacitor/Cooling Fan Replacement Timing.....	128
7.3.	How to Replace Cooling Fan.....	129
7.3.1.	How to Remove Cooling Fan.....	129
7.3.2.	How to Install Cooling Fan.....	132

7.4.	Inspecting and Replacing Main Circuit Capacitor.....	133
7.5.	How to Perform Insulation Resistance Test.....	133
7.6.	How to Discard Parts.....	134
Chapter 8	Replacing Control Board.....	135
8.1.	Tasks Required for Replacing Control Board.....	135
8.2.	How to Replace Control Board (For VFC66R-Z-P1).....	135
8.3.	How to Replace Control Board (For VFC66R-Z-P2).....	138
8.4.	How to Initialize Converter Main Unit.....	141
Chapter 9	Standard Specifications.....	146
9.1.	Common Specifications.....	146
9.2.	List of Models.....	147
Chapter 10	Outline Drawing of Converter.....	148
10.1.	Standard Type.....	148
10.2.	Non-standard Type (Heat Generation Part Protruded Outside).....	150
Chapter 11	VFC66R Parameter Compatibility Chart.....	151
11.1.	Basic Setting Area.....	151
11.2.	Area A (filter constant setting area).....	151
11.3.	Area b (operation command related setting area).....	151
11.4.	Area c (multifunction input/output related setting area).....	152
11.5.	Area E (control gain related setting area).....	152
11.6.	Area F (protection function/traceback setting area).....	153
11.7.	Area G (setting area for analog input and output).....	153
11.8.	Area J (communication option setting area).....	153
11.9.	Area o (special adjustment area).....	154
11.10.	Area P (special adjustment area).....	154
11.11.	Area S (converter capacity/DC voltage detection gain area).....	154
Chapter 12	Attentions for Contacting Us.....	155
Chapter 13	Industrial Product Warranty.....	156
13.1.	No-charge warranty Period.....	156
13.2.	Warranty Scope.....	156
13.2.1.	Problem diagnosis.....	156
13.2.2.	Repair.....	156
13.3.	Disclaimers.....	156
13.4.	Repair period after product discontinuation.....	156
13.5.	Delivery Condition.....	157

Preface

Thank you very much for choosing our converter.

This manual describes how to handle a main unit of the converter.

It provides instructions for using the converter, such as how to install, wire, and operate it correctly as well as handling methods of its protection operation.

Before operating it, be sure to carefully read this manual. Also, keep this manual in an appropriate place so that operators can always take and read it.

In addition to the standard functions, the converter provides many features. You can build an optimal system for different applications by using its various functions. In such a case, use the values described in the dedicated "Operating Instructions" and "Test Report" for the function.

When delivering any of your products with our converter built in, consider that this manual can be distributed to end users. Also, when changing our factory default initialized data (hereinafter referred to as Initialize.Val) for setting parameters of the converter, make sure that end users can be informed about the changed contents of the Initialize.Val.

Product Overview

Connecting VF66R to an inverter causes the regenerative energy from the motor to return to the power supply efficiently, which results in energy saving. Also, the power supply harmonics generated from an inverter can be suppressed significantly.

VF66R provides the PWM sine wave mode and 120-degree conduction mode.

The 120-degree conduction mode enables regenerative operation without high-speed switching since it energizes according to the phase of three-phase power supply voltage in turn so that the energization period of each phase becomes 120 degrees.

Be Sure To Read This Before Use

Safety Notice

To use the converter correctly, be sure to completely read this manual and all other attached documents before installation, operation, maintenance, and inspection.

You need to have a good knowledge of equipment, safety information, and all notices before using the converter.

In this manual, safety notices are ranked as "Danger," "Warning," and "Caution."



When improper use may cause a dangerous situation, death or serious injury may result, and its danger seems to be very urgent.



When improper use may cause a dangerous situation, death or serious injury may result, and its danger seems to be very urgent.



When improper use may cause a dangerous situation, and death or serious injury may result.



When improper use may cause a dangerous situation, and death or serious injury may result.



When improper use may cause a dangerous situation, medium-level or minor injury may result, and only physical damage may result. However, it can cause serious results depending on the situation. Cautions described in this manual are all important. Be sure to observe them.



When improper use may cause a dangerous situation, medium-level or minor injury may result, and only physical damage may result. However, it can cause serious results depending on the situation. Cautions described in this manual are all important. Be sure to observe them.

Caution Installation

- Install the converter on non-inflammables such as metal.
Otherwise, a fire may occur.
- Do not put inflammables near the converter.
Otherwise, a fire may occur.
- 75 kW and higher grade models are heavy. Do not attempt to raise it alone.
Otherwise, you may be injured.
- Do not hold the front cover when transporting the converter.
It may fall, which can result in injury.
- Install the converter in a place which can support its weight.
It may fall, which can result in injury.
- Do not install and operate the converter which is damaged or has a missing part.
Otherwise, you may be injured.
- Do not install the converter in an atmosphere which contains plasticizer such as halogen and DOP (phthalate ester).
Otherwise, it may be damaged.

Danger Wiring

- Before wiring, ensure that the input power supply is OFF and the system is disconnected from the power supply.
Otherwise, electric shock or a fire may occur.

Warning Wiring

- Be sure to connect a ground wire.
Otherwise, electric shock or a fire may occur.
- Electrical engineering technicians should connect wires.
Otherwise, electric shock or a fire may occur.
- Be sure to install the converter before wiring.
Otherwise, electric shock or a fire may occur.
- Do not directly connect a resistor between DC terminals [+]
and [-].
Otherwise, a fire may occur.

Warning Operation

- Be sure to install the front cover before turning on the input power. Do not remove the front cover during energization.
Otherwise, it can result in a risk of electric shock.
- Do not use operation keys by wet hands.
Otherwise, it can result in a risk of electric shock.
- Do not touch terminals such as main circuit terminals and a ground terminal during energization.
Otherwise, it can result in a risk of electric shock.
- The stop button ([STOP/RESET] key) is enabled only when functions have been set. Provide an emergency stop button separately.
Otherwise, you may be injured.
When alarm reset is performed with operation signals input, the converter suddenly restarts. Check that signals are turned off, and then perform alarm reset.
Otherwise, you may be injured.

Caution Operation

- Do not touch a heat sink and a discharge resistor because they reach high temperatures. Otherwise, you may get burned.

Warning Maintenance and inspection, and replacement of parts

- Before inspection, turn off the input power after checking that the operation is stopped, and then wait for over ten minutes. Also, check that DC voltage between the DC terminals [+] and [-] is less than or equal to 30 V. Otherwise, electric shock, injury, or a fire may occur.
- Do not perform maintenance and inspection or replace parts by anyone except qualified persons. Use a tool for insulation for maintenance and inspection. Otherwise, electric shock or injury may occur.

Warning Others

- Never modify the converter. Otherwise, electric shock or injury may occur.

Caution General notice

- To provide detailed explanation, all figures described in this manual are sometimes drawn with the cover or a safety shield removed. To operate the converter, be sure to return the specified cover or shield to its original position and to follow the procedure described in this manual.
- When the converter is packed with fumigated wooden materials, its electronic components may be fatally damaged. Be sure to use ways other than fumigation for sterilization and insect removal. Also, process them before packing.
- These safety notices and specifications in this manual are subject to change without notice.

Chapter 1 Checking and Inspecting Package

1.1. Checking Package and Inspection on Purchase

After receiving the converter, check the package, and then inspect the product and accessories.
If you have any problem, contact us or the distributor.

- (1) Check that the package contains the converter main unit and "Operating Instructions."

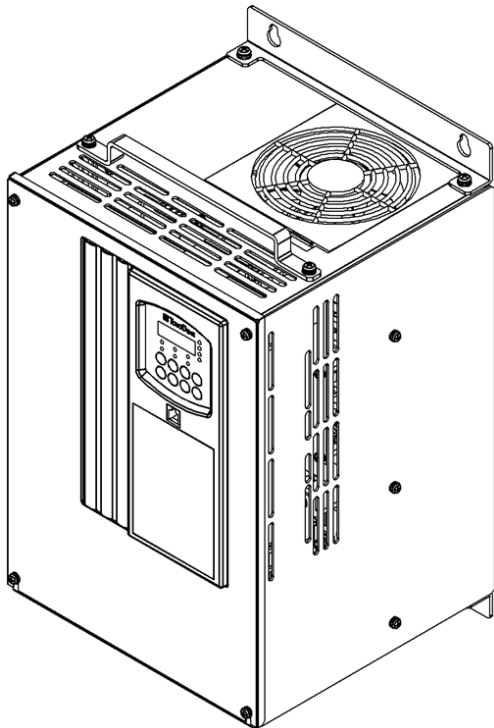

Converter main unit



Operating Instructions

- (2) Check that the specifications, accessories, spares, and options are delivered as you order.
You can check the converter model by seeing the model label on the surface of the cover.

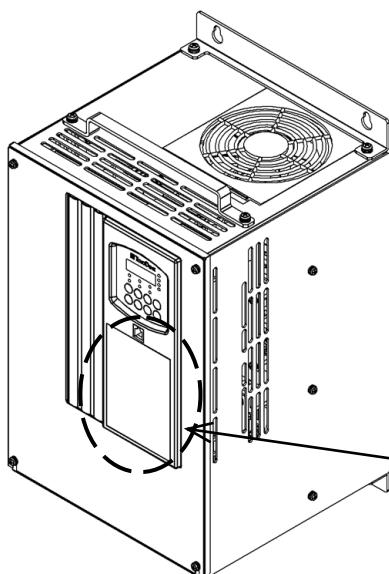

Model label

Example of the model label on the cover surface

<p style="text-align: center; font-size: 2em; font-weight: bold;">VF66R</p> <p>VF66R-7522</p> <p>TYPE VF66R-7522-W1</p> <p>APPL. QA1</p> <p>INPUT 3Φ 200~230V 50/60Hz</p> <p>OUTPUT 75kW</p> <p>WEIGHT 69kg</p> <p>SER. No. QC123456789-001</p> <p>⚠ 危険 けが、感電のおそれあり ・据え付け運転時の前に必ず取扱説明書を読んでその指示に従うこと。 ・通電中及び電源遮断後10分以内は正面カバーは開けないこと。 ・確実に接地を行うこと。</p> <p>⚠ 注意 火災のおそれあり ・金属などの不燃物に取り付けること。</p> <p>⚠ DANGER Risk of injury or electric shock. To avoid serious injury or shock. ・Read the manual prior to installation and follow safety instructions. ・Never remove the safety cover at power on and during 10 minutes after turning off the power. ・Must be grounded. Risk of fire ・Fix on nonflammable materials such as metal.</p>	<p>----- Converter series name (Indicates a sine wave PWM converter)</p> <p>----- Model: VF66R-7522-W1</p> <p style="margin-left: 20px;">----- Type</p> <p style="margin-left: 20px;">----- Voltage class 22: 200 V class 44: 400 V class</p> <p>----- Applied symbol</p> <p>----- Input power supply voltage specification</p> <p>----- Converter rated output power</p> <p>----- Weight</p> <p>----- Serial number</p>
---	---

(3) Check the product for damages and loose or removed screws during transportation.

Caution Safety notice

- To use the converter correctly, read this manual completely.
- Our converter is not designed and produced for the purpose of being used for a device or system under a situation where human life may be threatened.
- Do not use this converter for special purposes such as riding, medical, aerospace, nuclear power control, and a submarine repeater or system.
- This converter is produced under the strict quality control. However, when it is applied to an important facility where its failure might threaten human life or cause expected serious losses, you should install any safety devices to prevent serious accidents.
- This converter requires electrical work. Electrical engineering technicians should do it.

Chapter 2 Product Overview

2.1. Features

■ Equipped with the functions designed specially for power supply

Connecting VF66R to an inverter causes the regenerative energy from the motor to return to the power supply efficiently, which results in energy saving. Also, the power supply harmonics generated from an inverter can be suppressed significantly.

VF66R provides the PWM sine wave mode and 120-degree conduction mode.

The 120-degree conduction mode enables regenerative operation without high-speed switching since it energizes in turn according to the phase of three-phase power supply voltage so that the energization period of each phase becomes 120 degrees.

■ Reduced maintenance cost

Long-life parts are used for components which require replacement.

- Main circuit capacitor: About ten years (life expectancy in design)
- Cooling fan: About five years (life expectancy in design)

You can check the replacement timing with a cumulative operation timer.

2.2. Configuration

■ Converter main unit

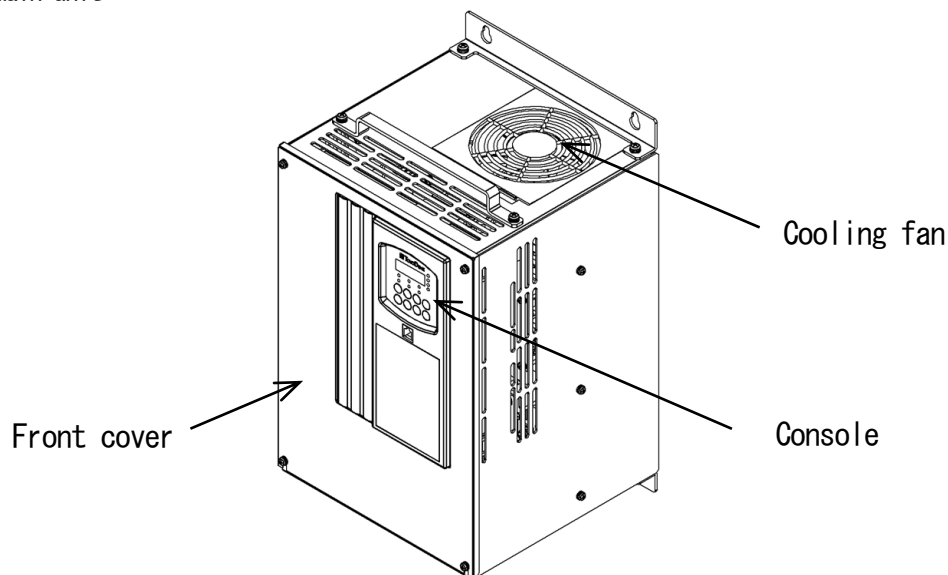

· Front cover

This is a front cover of the converter. For how to remove it, refer to {3.2.1. How to Open Front Cover}.

· Cooling fan

This is a fan motor for cooling. For how to replace it, refer to {7.3. How to Replace Cooling Fan}.

· Console

It is used for operation from the converter main unit.

It consists of a seven-segment display, a unit LED, a status display LED, and operation keys.

For details, refer to {4.2.1. Explanation of Display and Operation Keys on Console}.

■ Circuit board

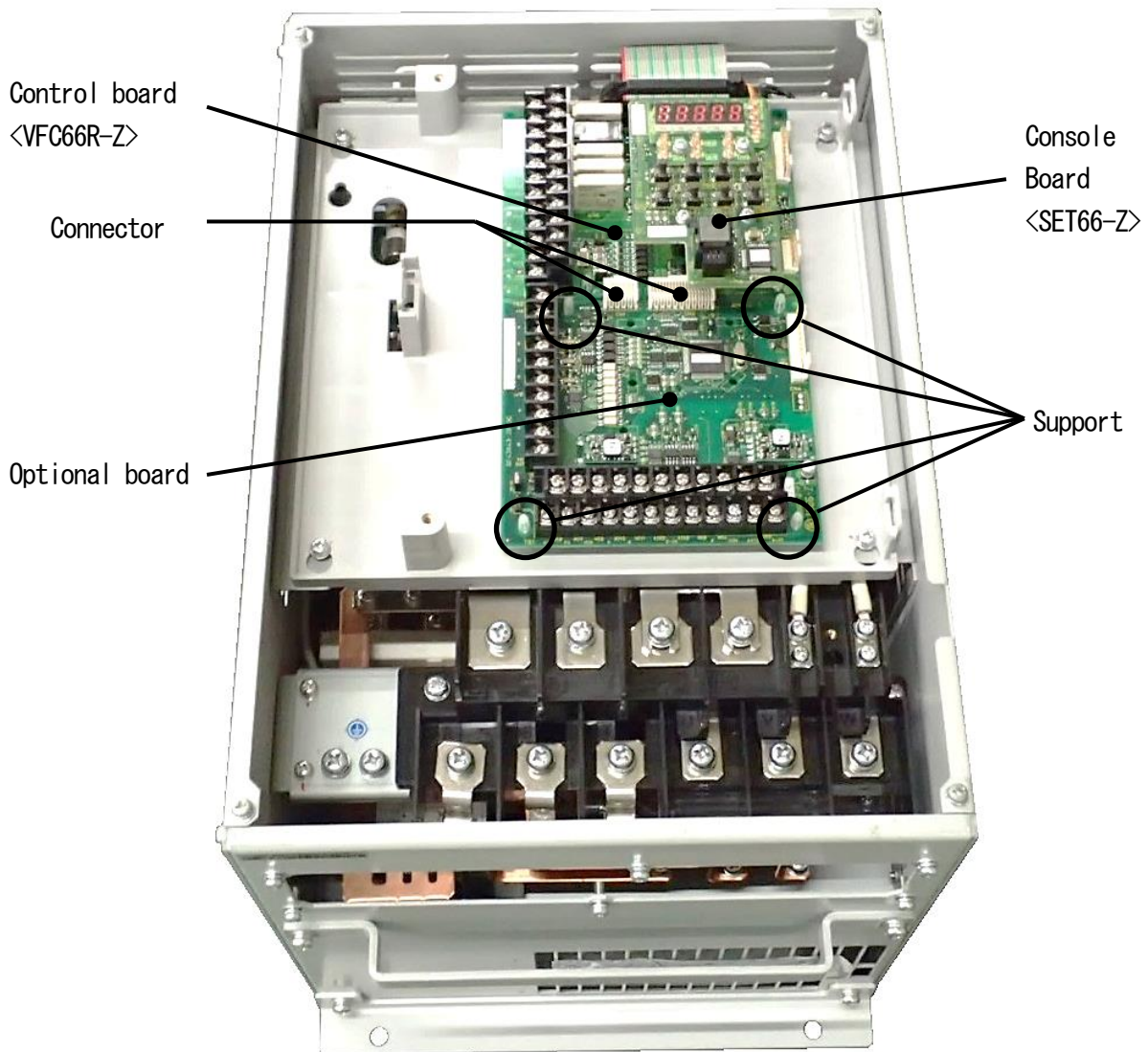

• **Terminal block**

For details of wiring, refer to [3.3.1. How to Connect Converter Terminals] and [3.5. Notes for Wiring and Electrical Wire Size]. For details of the terminal block, refer to [3.4. Terminal Specifications].

• **Control board <VFC66R-Z>**

This is a control part of the converter. A terminal block is located on the left side.

For details of wiring, refer to [3.3.1. How to Connect Converter Terminals] and [3.5.3. Electrical Wire Size of Control Board]. For details of the terminal block, refer to [3.4. Terminal Specifications]. For how to replace the control board <VFC66R-Z>, refer to [8.2. How to Replace Control Board].

• **Console board <SET66-Z>**

This is a console part of the converter. It has LEDs and operation keys.

• **Optional boards**

Optional boards are used to add external input/output, etc.

Chapter 3 How to Install and Connect Converter

3.1. Installation Environment and How to Install

3.1.1. Installation Environment

Install the converter in an environment not exceeding the overvoltage category III or the pollution degree 2 defined by the IEC60664-1.

Overvoltage category

Overvoltage category	Equipment	Equipment overview
I	Secondary circuit	Equipment connecting to a circuit where any measures are taken to limit transient overvoltage to a lower level. It includes a protected electronic circuit.
II	Home electrical appliance and office machine	Equipment consuming energy supplied from a fixed wiring facility.
III	Electrical facility	Equipment in the fixed wiring facility which especially requires reliability and effectiveness.
IV	Power receiving	Equipment used for a service entrance.

Pollution degree

Pollution degree	Overview	Specific example
1	There is no pollution, or only dry and non-conductive pollution occurs. This type of pollution has no effect.	Clean room and others
2	Typically, only non-conductive pollution occurs. However, when the system is not running, temporary conductivity can be expected due to condensation.	Electrical equipment in an office and a control panel, and others
3	Conductive pollution, or dry and non-conductive pollution resulting in conductivity due to expected condensation occurs.	In a general factory and others
4	Pollution causes continuous conductivity due to conductive dust, rain, and snow.	Outdoor and others

3.1.2. How to Install Converter

■ Requirements of where to install the converter

Installation conditions of the converter will greatly affect its life and reliability. Avoid installing it in the places listed below. Use it under the environmental conditions described in {Chapter 9 Standard Specifications}.

- (1) In a humid and dusty area or a place where water or oil drips, the insulation of circuits is deteriorated, which may reduce the life of parts.
- (2) Too high ambient temperature will cause the life of the main circuit capacitor or the cooling fan to be reduced.
- (3) In a place containing corrosive gas, connectors may have a loose connection, electrical wires may be disconnected, and parts may be damaged.

(4) In a place having many vibrations, connectors may have a loose connection, electrical wires may be disconnected, and parts may be damaged.

(5) When using the converter in a place where ambient temperature is below 0 °C, use a heater, etc. to ensure that it becomes 0 °C or higher at the start of the converter. After it starts, when the temperature becomes 0 °C or higher due to its heat generation, there is no problem.

■ Action after short-circuit

Dispose of a short-circuited converter in any circumstances without using it.

Caution Installation

- Install the converter on non-inflammables such as metal.
Otherwise, a fire may occur.
- Do not put inflammables near the converter.
Otherwise, a fire may occur.
- 75 kW and higher grade models are heavy. Do not attempt to raise it alone.
Otherwise, you may be injured.
- Do not hold the front cover when transporting the converter.
It may fall, which can result in injury.
- Install the converter in a place which can support its weight.
It may fall, which can result in injury.
- Do not install and operate the converter which is damaged or has a missing part.
Otherwise, you may be injured.
- Do not install the converter in an atmosphere which contains plasticizer such as halogen and DOP (phthalate ester).
Otherwise, it may be damaged.

■ Converter installation requirements and heat radiation

To use the converter, incorporate it into the control board, etc. to meet the environmental conditions for installation.

Warning How to install converter

- Install it correctly.
Incorrect installation can result in a risk of electric shock or a fire.

• Installation orientation and intake/exhaust direction

Install the converter vertically with a cooling fan facing up. When it is installed sideways, ventilation is prevented, which may increase temperature. You should sufficiently consider a path of intake and exhaust. The cooling fan built in the converter sucks air from the bottom and exhausts it to the top. To prevent a wiring duct, etc. from blocking up the vent, keep enough space.

• Keeping cooling space

To install the converter, keep a cooling space.

When heat generation devices exist in the surrounding environment, place them so that they do not affect cooling of the converter and others.

The operating temperatures of the converter are 0 to 50 °C. To install it in the control board, perform ventilation to ensure that the temperature in the board is below 50 °C. High ambient temperature will decrease reliability.

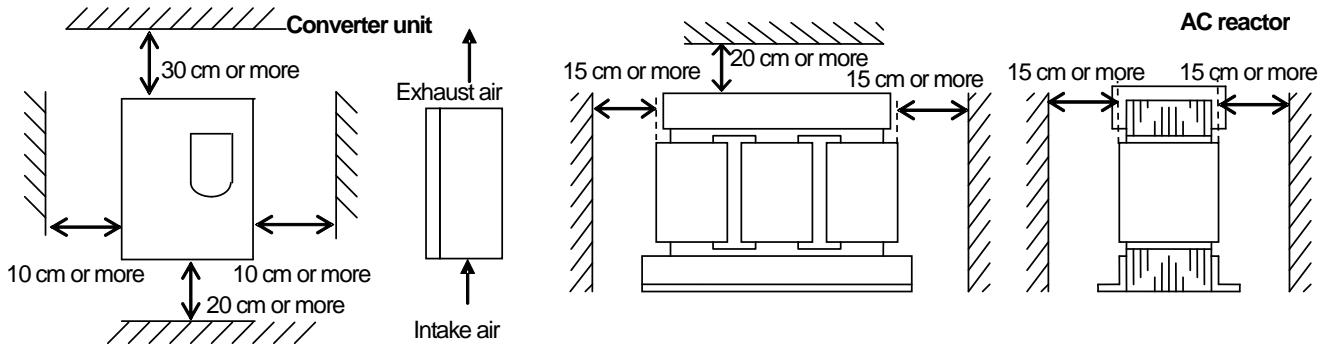

3.2. How to Open and Close Front Cover



Warning Opening and closing front cover

- Be sure to turn off the converter when opening and closing the front cover. Otherwise, it can result in a risk of electric shock.

3.2.1. How to Open Front Cover

To work inside the converter (such as connecting or wiring terminals, and maintenance/inspection), follow the steps below to open the front cover.

■ For models using a sheet-metal chassis and front cover

Remove the sheet-metal front cover and the resin control part cover.

1. Use the Phillips screwdriver (M4) to remove the mounting screws at the top of the front cover.
2. Loosen the screws at the bottom of it.
3. Remove the front cover from the main unit.

· The number of mounting screws at the top and bottom of the front cover depends on the model. Refer to the figure below.

(For VF66R-7522, 9022 (15022, 18022)
7544, 11044, 16044)

Front cover mounting screw
(Upper cover: 5 pcs)
(Lower cover: 5 pcs)

Upper cover
Lower cover

Just loosen the lower screws to
remove the covers

(For VF66R-20044, 25044, 31544
(40044~100044))

Front cover mounting screw
(Upper cover: 5 pcs)
(Lower cover: 5 pcs)

Just loosen the lower screws to
remove the covers

4. When the control part cover is vibration resistant, use the Phillips screwdriver (M4) to remove two mounting screws of the control part cover.

· When it is not vibration resistant, it does not have mounting screws.

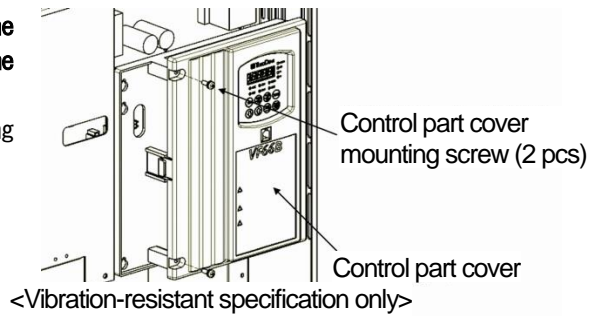

5. While holding the lock part of the control part cover with your thumb, pull it and remove it, using the two claws on the right side as supporting points.

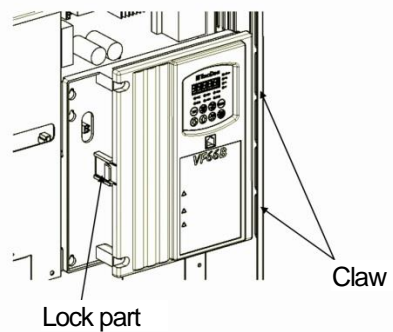

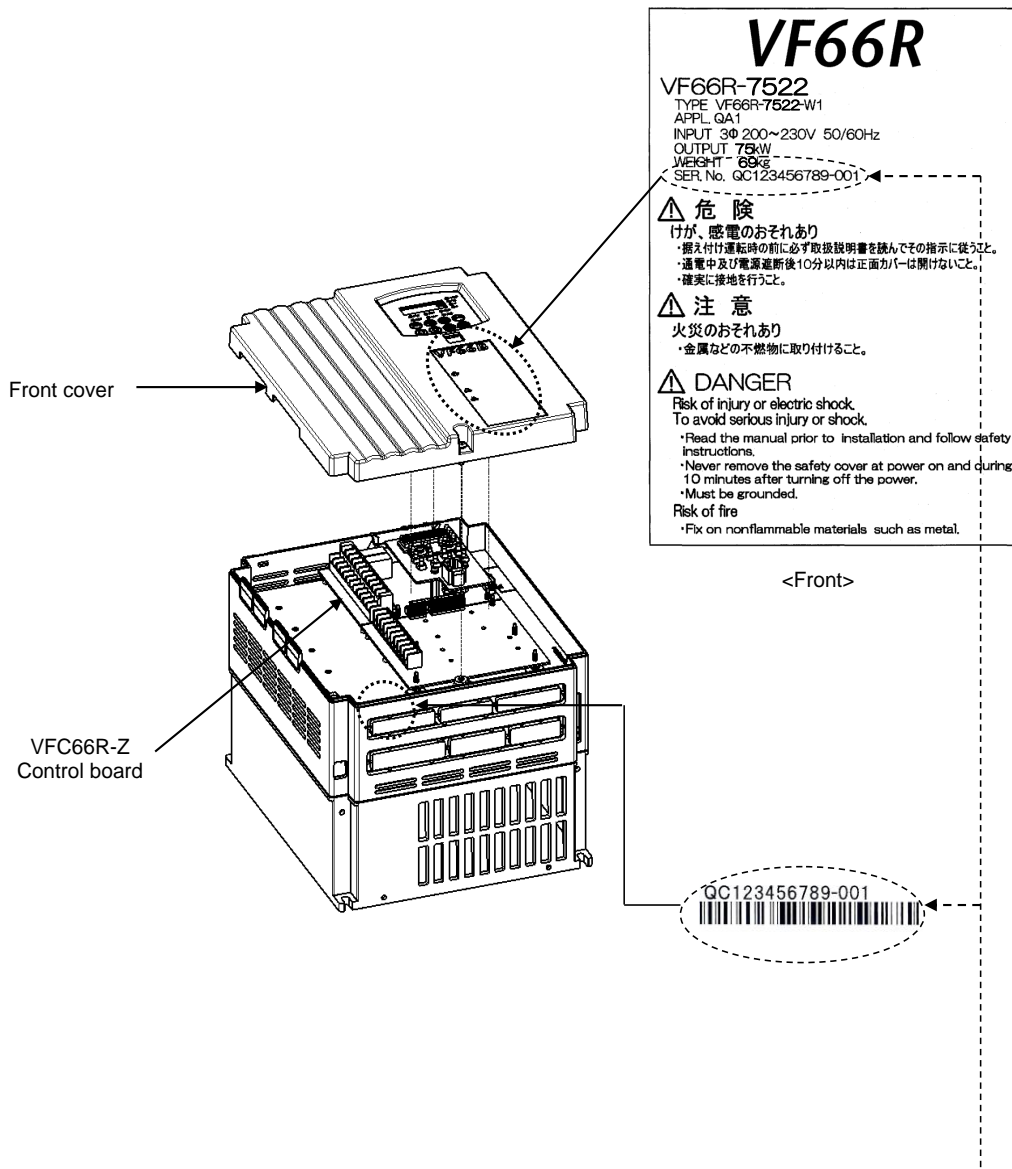

* Check that the serial number specified on the front cover agrees with that specified outside the inverter.

Warning Notes for replacing parts

- Do not disassemble the converter unreasonably.
- After disassembling it, check that all parts are assembled correctly. Incorrect assembly can result in a risk of a fire.
- In particular, if a flat cable is not inserted correctly, the control circuit may not work properly.
- Make sure that screws are tightened.

3.2.2. How to Close Front Cover

Follow the steps below to close the front cover of the converter.

When closing the front cover, ensure that the serial number described in the main unit matches the one described on the front cover. For how to check the serial number, refer to {3.2.1. How to Open Front Cover}.

■ For models using a sheet-metal chassis and front cover

Install the resin control part cover and the sheet-metal front cover.

1. Insert the two claws on the right side of the control part cover into the sockets of the converter main unit.

2. Push them until a lock clicks.

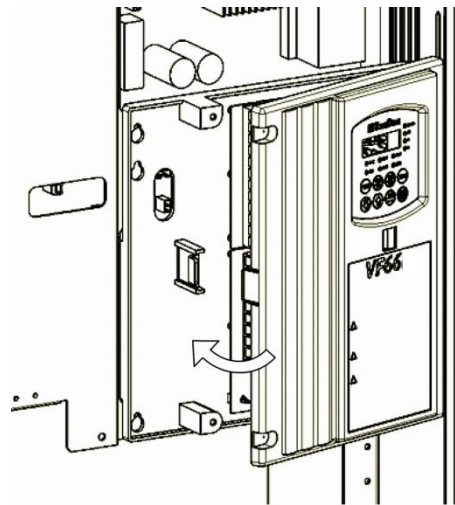

3. When the control part cover is vibration resistant, use the Phillips screwdriver (M4) to tighten the two mounting screws of the control part cover.

- Tighten it within a tightening torque of 1.4 N·m.
- When it is not vibration resistant, it does not have mounting screws.

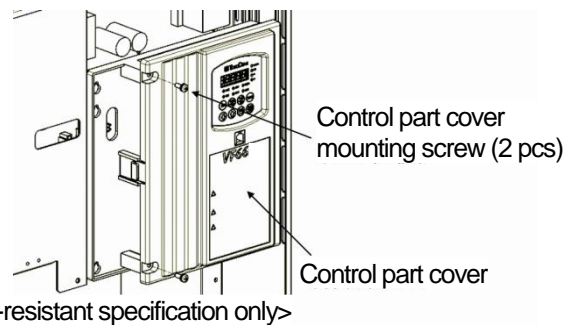

4. Use the Phillips screwdriver (M4) to tighten the mounting screws of the front cover.

- Tighten it within a tightening torque of 1.5 N·m.
- The number of mounting screws of the front cover depends on the model. Refer to the figure below.

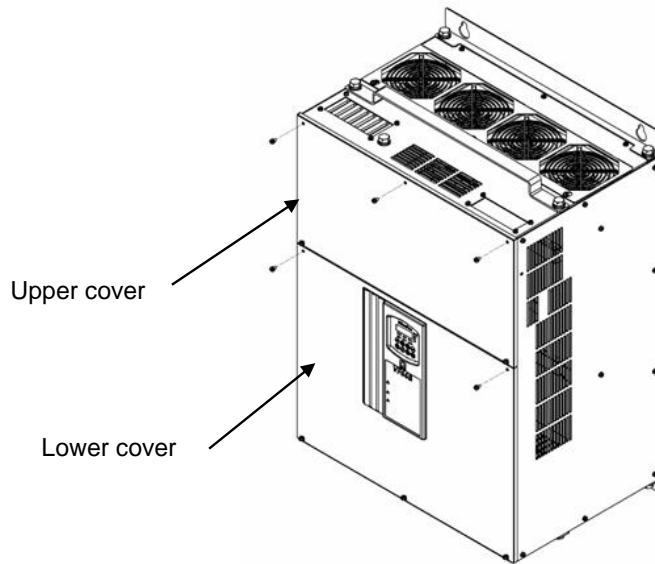

VF66R-7522, 9022

7544, 11044, 16044

Mounting screw: Upper cover 4 pcs

Lower cover 4 pcs

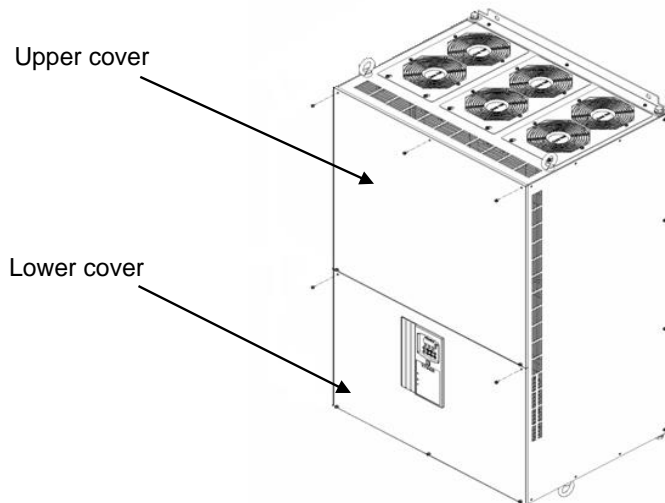

VF66R-20044, 25044, 31544

Mounting screw: Upper cover 5 pcs

Lower cover 5 pcs

3.3. How to Connect Converter

3.3.1. How to Connect Converter Terminals

The figure below shows the connection diagram of the converter (VF66R-7522, 9022, and 7544 through 31544) terminals.

For specifications of each terminal, refer to [3.4. Terminal Specifications].

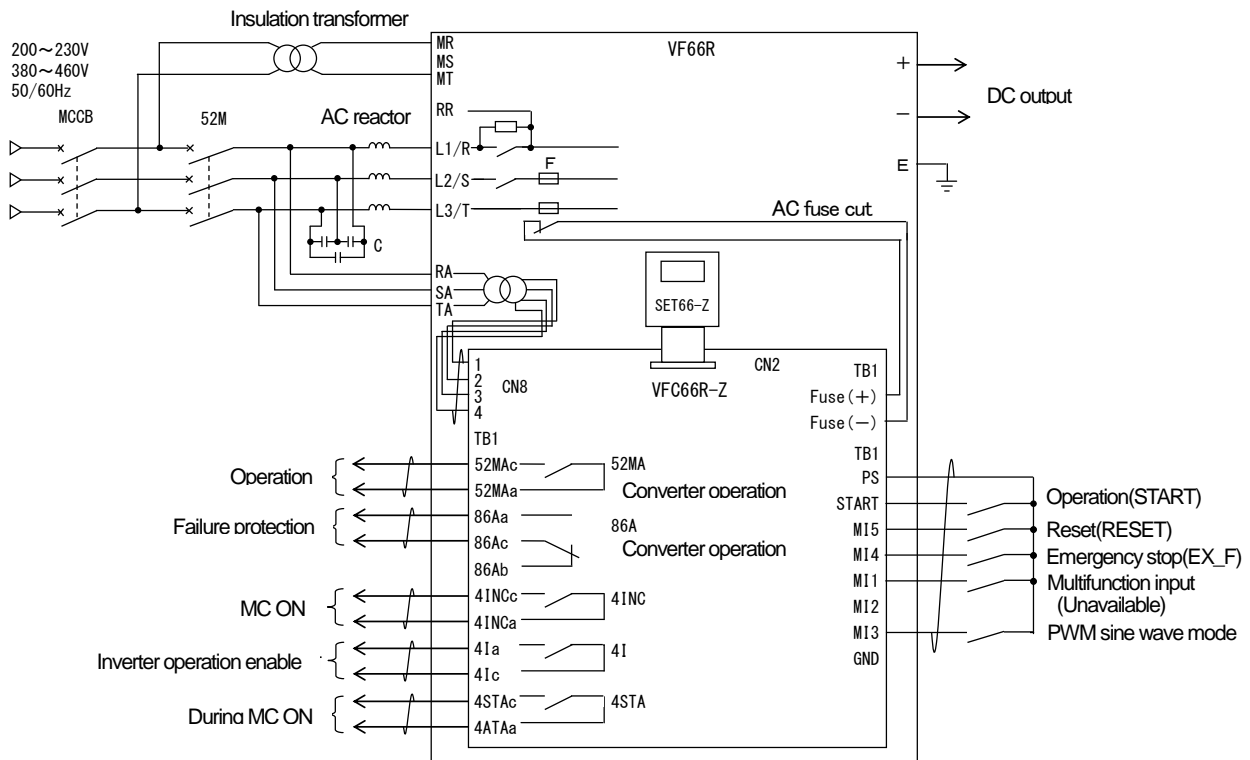

- (1) Input the specified input voltage. Inputting 400 V to the 200 V class converter damages the unit and causes a very dangerous situation.
- (2) Be sure to connect MCCB of appropriate capacity to the main circuit input side.
- (3) Be sure to connect the power supply line to RA, SA and TA. Connect so that the main circuit terminals [L1/R], [L2/S] and [L3/T] correspond to RA, SA and TA, respectively.
- (4) Be sure to connect to the ground terminal for safety reasons.
- (5) To connect five or more inverters between the converter outputs of [+] and [-], you may need to connect an adjustment resistor between the RR and R terminals. In this case, contact us.
- (6) The AC power supply terminals [MR] and [MT] for the control circuit are not connected to the power supply in normal situations. Connect them when the control circuit power needs to be turned on after turning off the main circuit power. Be sure to insulate from the main circuits of [L1/R], [L2/S] and [L3/T] using a transformer.

When the control power supply terminals [MR] and [MT] are used in parallel models (VF66R-15022, 18022, and 40044 through 100044), power should be supplied to not only a master unit but a slave unit.

- (7) The AC reactor used in the PWM sine wave mode is different from that used in the 120-degree conduction mode. Be sure to use the AC reactors specified by Toyo Denki.
- (8) A filter capacitor is required in the PWM sine wave mode. It is not used in the 120-degree conduction mode. Be sure to use the filter capacitor specified by Toyo Denki.
- (9) Never connect the GND and COM terminals of the control circuit to the ground terminal.
- (10) In the factory default, the control input terminal [START] and multifunction input terminals [MI1] through [MI5] are set to PS common input (source input). When changing them to GND common input (sync input), remove a jumper socket on the control board <VFC66R-Z> from [CN-S0] and then attach it to [CN-S1].

Changing a short-circuit wire

To use the VF66R-31544 or 16044 converter at a power supply voltage of 460 V, you need to change a short-circuit wire.

Power supply voltage used for the converter

- 380 to 440V: Short circuit between [MCA] and [RA] on the terminal block shown on the right.
- 460V: Short circuit between [MCA] and [RA1] on the terminal block shown on the right.

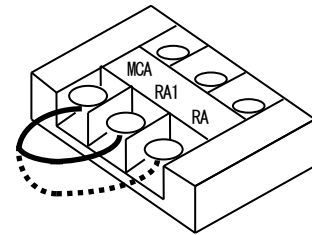

*** Notes for connecting multiple inverters to the converter**

1. Up to five inverters can be connected to a single converter.

Be sure to select the converter having a rated capacity larger than the total capacity of inverters to use.

For example, when total five 400 V class inverters of 11, 15, 22, 37 and 45 kW are used, the total capacity is 130 kW and therefore VF66R-16044 should be selected.

Note that in using the PWM sine wave mode, the effect of suppressing distortion of power supply current is decreased at a capacity half the converter rated capacity or less. In this case, it is possible to use as a converter. To produce the harmonic suppression effect, however, it is recommended that the load on the converter be more than half of the rated capacity.

2. To use the converter as a common converter for multiple inverters, connection of a resistor between the terminals R and RR may be needed depending on the number of inverters to be connected.

For the resistance value and model, contact us.



- Never touch the terminals while the converter is energized. A voltage is applied to the converter output terminals even in the stopped state. Otherwise, it can result in a risk of electric shock.

3.4. Terminal Specifications

Main circuit

Terminal number	Purpose	Description
R/L1, S/L2, T/L3	Spare	Unconnected
L1/R, L2/S, L3/T	Converter input	<ul style="list-style-type: none"> · PWM sine wave mode: Connected to the AC power supply through the AC reactor for the PWM sine wave mode and filter capacitor. · 120-degree conduction mode: Connected to the AC power supply through the AC reactor for the 120-degree conduction mode. (Never input 400 V to the 200 V class converter.)
+, -	Converter DC output	Connect the DC input terminals of the inverter to be connected to the converter. Do not connect the power supply to the inverter terminals R/L1, S/L2 and T/L3.
B	Spare	Unconnected
	Ground terminal	[Caution] Be sure to connect it to the ground. When using a noise filter, connect it to a ground terminal of the filter.
MR, MS, MT	Control power supply terminal	<ul style="list-style-type: none"> · Operation is available without connecting these terminals. · Used when power is supplied to the control circuit only. · Connect the AC power supply between [MR] and [MT], not [MS]. · Connect to the main circuit through an insulation transformer. [Caution] When used in parallel models (<15022>, <18022>, and <40044> through <100044>), power should be supplied to not only a master unit but a slave unit.
RA, SA, TA	Voltage detection	Connect the AC input power supply. Be sure to connect this terminal. Connect so that the converter main circuit terminals L1/R, L2/S and L3/T correspond to RA, SA and TA, respectively. A wrong connection causes malfunction of the converter.

Terminal block <TB1> on the control board <VFC66R-Z>

Terminal number	Purpose	Description
52MA	Operation contact	Turns on while the converter is operated. Contact rating 250 VAC, 30 VDC, 2 A
86A	Protection contact	86Aa-86Ac turns on and 86Ab-86Ac turns off while the converter takes the protection operation. Contact rating 250 VAC, 110 VDC, 0.3 A
4INC	External MC input permission	External MC input permission turns on. Contact rating 250 VAC, 30 VDC, 2 A
4I	Inverter operation enable	Turns on when an inverter is permitted to run. Disable starting an inverter while this relay is OFF, connecting this terminal to the emergency stop (Normally closed), etc. of the inverter. Contact rating 250 VAC, 30 VDC, 2 A
4STA	During MC ON	Turns on while the MC contact inside the converter unit is ON. Contact rating 250 VAC, 30 VDC, 2 A
START	Operation signal	Input terminal for operation signal
PS	+12V output	Output +12 V DC voltage.
MI1	Multifunction input terminal (1)	Multifunction input
PS	+12V output	<ul style="list-style-type: none"> • Maximum input voltage 24 VDC, maximum input current 3 mA ■ Initial state (fixed functions) • Multifunction input terminal (1): Multifunction input terminal • Multifunction input terminal (2): Multifunction input terminal (2) • Multifunction input terminal (3): Unused (internal PLC function available) • Multifunction input terminal (4): Mode switch (ON: PWM OFF: 120-degree conduction) • Multifunction input terminal (5): Emergency stop (Normally open) • Multifunction input terminal (5): Protection reset
MI2	Multifunction input terminal (2)	
MI3	Multifunction input terminal (3)	
MI4	Multifunction input terminal (4)	
GND	GND terminal	
MI5	Multifunction input terminal (5)	
GND	GND terminal	[Caution] Do not connect the terminal [GND] to the ground terminal.
FUSE(-)	Negative side input of AC fuse	Detect a blown AC fuse.
FUSE(+)	Positive side input of AC fuse	

■ Terminal layout of main circuit terminals

- VF66R-7522 and 9022
VF66R-7544 through 16044

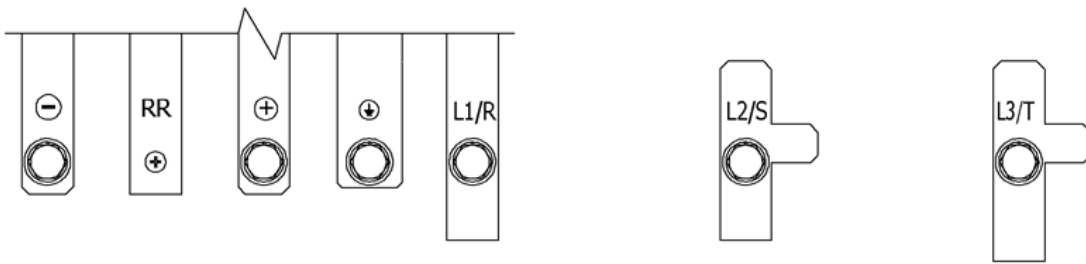

- VF66R-20044 through 31544

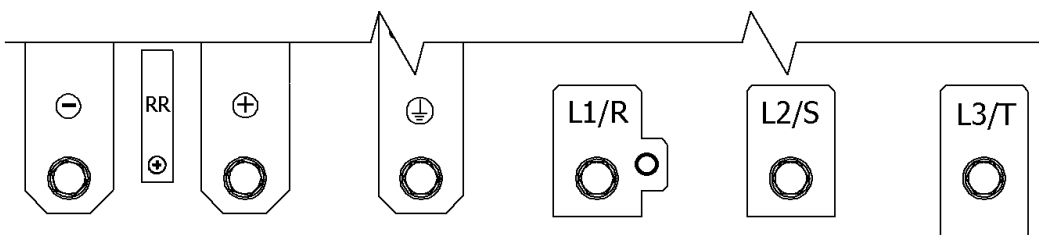

3.5. Notes for Wiring and Electrical Wire Size

3.5.1. Notes for Wiring

- (1) Input the specified voltage into the converter terminals [L1/R], [L2/S], [L3/T], [+] and [-].
 - If you input the voltage specified for the 400 V class into the 200 V class converter, the converter will be damaged.
 - If you input the voltage specified for the 200 V class into the 400 V class converter, it may lead to malfunction or damage to the converter.
- (2) IGBT is used in the converter, and the converter operates at a high frequency. Therefore, noise is emitted. Consider the following points for wiring:
 - Keep main circuit wires away from a control signal wire. When placing them in parallel, keep a distance of 30 cm or longer between them.
 - When crossing them, ensure that they are crossed at right angles.
 - It is recommended that the main circuit wire should be contained into a metal pipe as a measure against noise for other facilities.

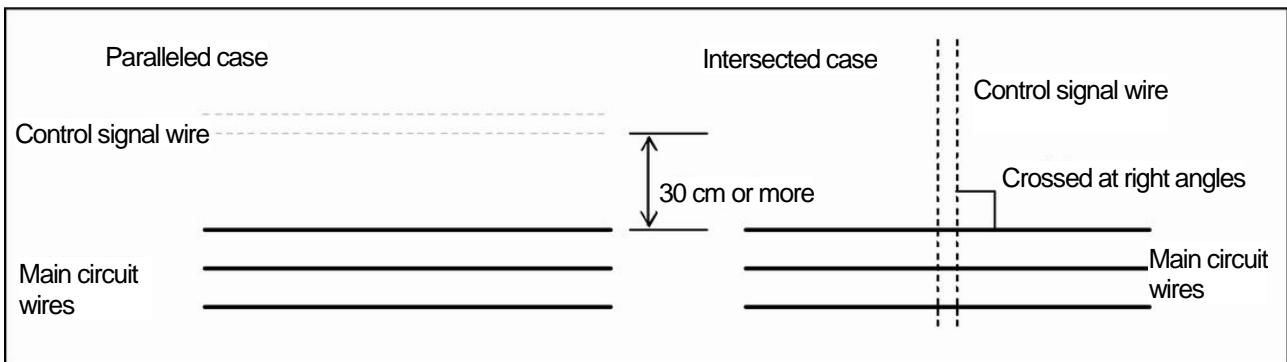

- (3) To prevent noise contamination, use a shielded wire or a shielded twisted pair wire for the control signal wire.
- (4) When the wiring of the 400 V class converter is 100 m or longer in length
Due to the wiring, surge voltage may be generated in the device connected to the output terminal.
Take the following measure:
 - Connect a surge voltage suppression filter on the converter side.

3.5.2. Electrical Wire Size of Input/Output Device and Main Circuit Wires

The electrical wire size of main circuit wires depends on the converter model.

See the table below to use appropriate electrical wires for connection.

■ 200 V class

Converter model	Main circuit contactor		Wiring size [mm ²] ⁽⁴⁾				
	Input MCCB ⁽²⁾	Input MC ⁽³⁾	Input side (AC)		Output side (DC)		Ground wire ⁽⁵⁾
			Inside board	Outside board	Inside board	Outside board	
VF66R-7522	400A	S-N400	150	150	150	150	22
VF66R-9022	400A	S-N400	150	150	200	200	38
VF66R-15022	800A	-	150	150	150	150	22
VF66R-18022	800A	-	150	150	200	200	38

■ 400 V class

Converter model	Main circuit contactor		Wiring size [mm ²] ⁽⁴⁾				
	Input MCCB ⁽²⁾	Input MC ⁽³⁾	Input side (AC)		Output side (DC)		Ground wire ⁽⁵⁾
			Inside board	Outside board	Inside board	Outside board	
VF66R-7544	200A	S-N200	60	60	60	60	14
VF66R-11044	300A	S-N300	80	80	100	100	22
VF66R-16044	400A	S-N400	150	150	200	200	22
VF66R-20044	500A	S-N600	200	200	200	200	38
VF66R-25044	600A	S-N600	250	250	150 x 2P ⁽⁶⁾	150 x 2P ⁽⁶⁾	38
VF66R-31544	700A	S-N800	150 x 2P ⁽⁶⁾	150 x 2P ⁽⁶⁾	150 x 2P ⁽⁶⁾	150 x 2P ⁽⁶⁾	50
VF66R-40044	1000A	-	200	200	200	200	38
VF66R-50044	1200A	-	250	150 x 2P ⁽⁶⁾	250	150 x 2P ⁽⁶⁾	38
VF66R-60044	1500A	-	200	200	200	200	38
VF66R-75044	2000A	-	250	150 x 2P ⁽⁶⁾	250	150 x 2P ⁽⁶⁾	38
VF66R-100044	2500A	-	250	150 x 2P ⁽⁶⁾	250	150 x 2P ⁽⁶⁾	38

- (1) This table is based on the input voltage of 200 VAC for the 200 V class and 380 VAC for the 400 V class.
- (2) Input MCCB indicates the rated current values. Determine the breaking capacity of MCCB based on the power supply capacity, etc. Select a ground fault interrupter for the inverter.
- (3) Input MC is selected based on the rated energizing current. Select an appropriate one as needed according to the opening/closing frequency.
- (4) Plan the wiring between the converter and power supply so that voltage drop is below 2 %. The table lists wire size for inside the board (3 m in length as MLFC) and for outside the board (30 m in length as CV (three single-core)).
- (5) Use the ground wire with many element wires, such as KIV.
- (6) Use the solderless terminal CB200-S12 manufactured by J.S.T. MFG. CO., LTD.
- (7) Use the R type solderless terminal standardized by Japanese Industrial Standards (JIS C 2805) or the UL/cUL approved round solderless terminal.
- (8) Use "150-L12" for the solderless terminal.

3.5.3. Electrical Wire Size of Control Board

The electrical wire size of the terminal block TB1 on the control board <VFC66R-Z> is common to all converter models.

Terminal block	Wiring size [mm ²]
Terminal block TB1 on the control board <VFC66R-Z> ([52MA] - [FUSE(+)])	0.12 - 0.32 [AWG26 to 22]

3.6. AC Filter

3.6.1. AC Reactor

The following tables show the AC reactors provided for the PWM sine wave mode.

For the AC reactors provided for the 120-degree conduction mode, contact us.

200 V class	
Converter model	AC reactor model
VF66R-7522	ACL7522
VF66R-9022	ACL9022
VF66R-15022	ACL7522 x 2
VF66R-18022	ACL9022 x 2

400V class	
Converter model	AC reactor model
VF66R-7544	ACL7544
VF66R-11044	ACL11044
VF66R-16044	ACL16044
VF66R-20044	ACL20044
VF66R-25044	ACL25044
VF66R-31544	ACL31544
VF66R-40044	ACL20044 x 2
VF66R-50044	ACL25044 x 2
VF66R-60044	ACL20044 x 3
VF66R-75044	ACL25044 x 3
VF66R-100044	ACL25044 x 4

● Exterior and dimensions (reference)

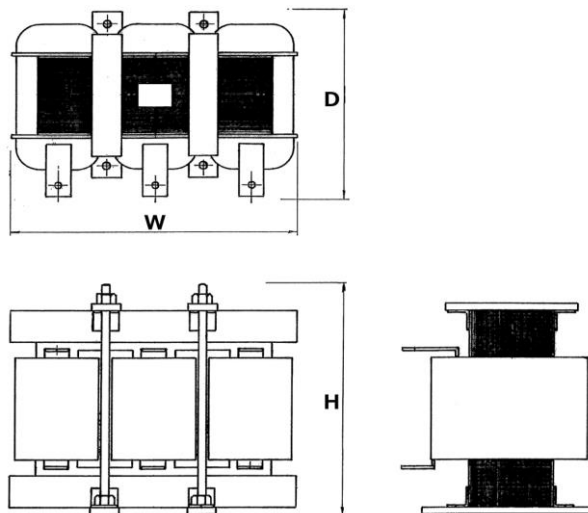

Model	W	H	D	Weight	Model	W	H	D	Weight
ACL7522	300	320	295	58	ACL7544	300	310	290	63
ACL9022	300	320	295	65	ACL11044	360	380	320	96
					ACL16044	420	400	340	125
					ACL20044	420	460	340	150
					ACL25044	450	520	370	190
					ACL31544	480	550	400	240

(Note) Units of dimension and weight are mm and kg, respectively.

3.6.2. AC Filter Capacitor

The following tables show the AC filter capacitors provided for the PWM sine wave mode.

To use two or more capacitors arranged side by side, keep a space of at least 25 mm between adjacent capacitors.

AC filter capacitor is not used for the 120-degree conduction mode.

200 V class	
Converter model	AC filter capacitor model
VF66R-7522	QS24745-8R
VF66R-9022	QS24745-9R
VF66R-15022	QS24745-8R x 2
VF66R-18022	QS24745-9R x 2

400 V class	
Converter model	AC filter capacitor model
VF66R-7544	QS24746-8R
VF66R-11044	QS24746-9R
VF66R-16044	QS24746-10R
VF66R-20044	QS24746-11R
VF66R-25044	QS24746-12R
VF66R-31544	QS24746-13R x 2
VF66R-40044	QS24746-11R x 2
VF66R-50044	QS24746-12R x 2
VF66R-60044	QS24746-11R x 3
VF66R-75044	QS24746-12R x 3
VF66R-100044	QS24746-12R x 4

● Exterior and dimensions (reference)

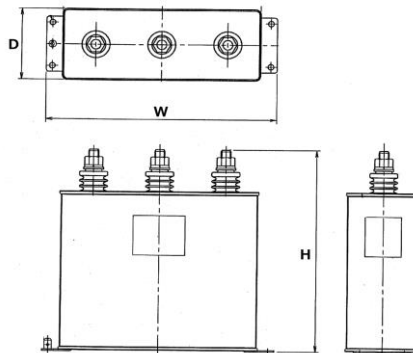

AC filter capacitor model	W	H	D	Weight t	AC filter capacitor model	W	H	D	Weight
QS24745-8R	280	260	90	6.0	QS24746-8R	280	210	90	4.5
QS24745-9R	280	260	90	6.0	QS24746-9R	280	260	90	5.5
					QS24746-10R	280	290	90	6.5
					QS24746-11R	435	350	100	15
					QS24746-12R	435	350	100	15
					QS24746-13R	280	290	90	6.5

(Note) Units of dimension and weight are mm and kg, respectively. AC reactors and AC filter capacitors need to be resistant to switching ripple current.

Contact us for these items.

Chapter 4 Basic Operating Procedures for Converter

4.1. Checks before Starting Operation

4.1.1. About the Control Mode

The VF66R converter provides two control modes: PWM sine wave mode and 120-degree conduction mode.

You can check which mode is selected with the console display at power-on or setting item: <n-00>.

The console display shows "VF66r" for the PWM sine wave mode or "Vr120" for the 120-degree conduction mode.

(Note) Normally, the unit is shipped with the control mode specified by order.

Notes

- Note that the AC reactor used in the PWM sine wave mode is different from that used in the 120-degree conduction mode.
- The PWM sine wave mode uses a filter capacitor, whereas the 120-degree conduction mode does not. Keep this in mind.
- With the PWM sine wave mode selected, the terminal MI3 on the terminal block TB1 on the control board <VFC66R-Z> needs to be input. If the terminal MI3 is not input with the PWM sine wave mode selected, the converter cannot be operated. Conversely, if the terminal MI3 is input with the 120-degree conduction mode selected, the converter cannot be operated. Keep this in mind.

4.1.2. Minimum Parameter Settings

1. Power supply frequency

Set via the basic setting item "2.FrEq."

2. Electric constant of filter

To use the unit in the PWM sine wave mode, check that the constants of the AC reactor and filter capacitor (specified by Toyo Denki) connected to the VF66R converter are correctly set in the items: <A-00> and <A-01> in the setting area. (The values of the AC reactor and filter capacitor specified by Toyo Denki are set at the time of the control board <VFC66R-Z> initialization.)

Be sure to use the AC reactor and filter capacitor specified by Toyo Denki.

4.1.3. Replacing Control Board <VFC66R-Z> with Spare

To make a spare compatible with the currently used converter, gain adjustments of analog circuits, such as converter capacity and DC voltage detection part are necessary.

4.2. Basic Operating Procedures from Console

4.2.1. Explanation of Display and Operation Keys on Console

On the console of the converter, you can operate it, read and write each function setting data, display operating states, and display what are protected during protection operations.

The console consists of the components listed below: displays 1 through 3 and operation keys 4.

- 1: Seven-segment display
- 2: Unit LED
- 3: Status display LED
- 4: Operation keys

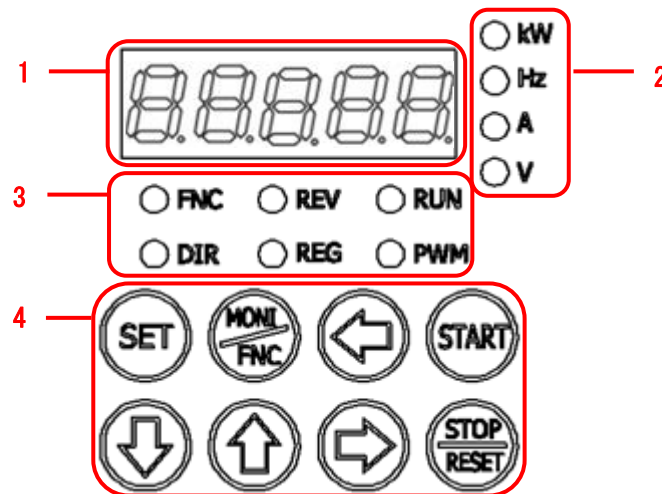

Converter operation

- In addition to using the console described below, you can operate the converter and set various functions in the following ways:
 - External console option <SET66R-Z>
 - Contact input and analog input
 - Control through external digital communication
 - Internal PLC function
- Sometimes you cannot operate the converter from the console, depending on settings.

■ Overview of the operation from the console

The console provides three types of operation modes.

- Monitor (MONI) mode
- Function setting (FNC) mode
- Protection display mode

The operation overview is described below.

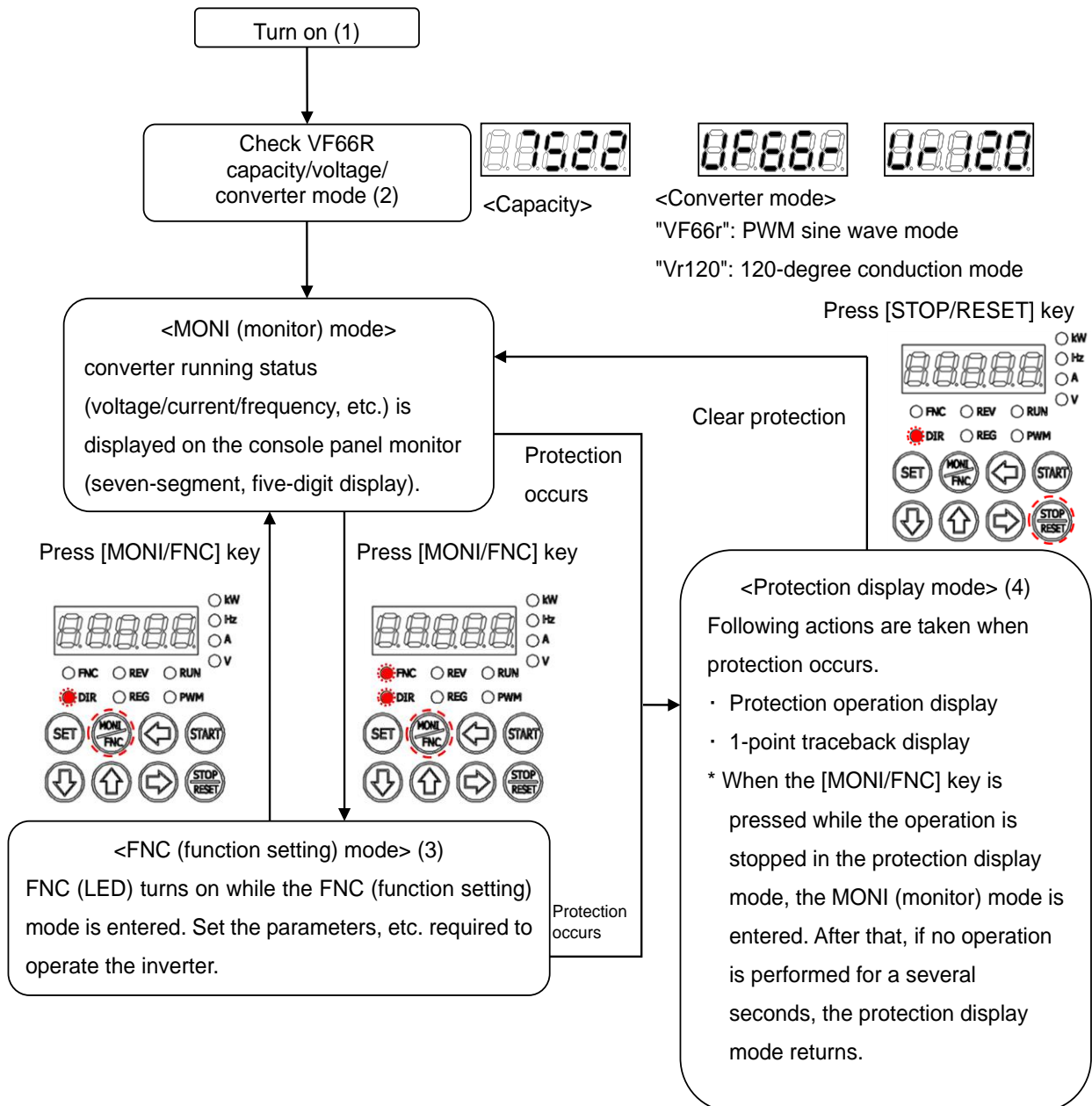

- (1) For what are displayed at power-on and their details, refer to {4.2.2. What Are Displayed at Power-on}.
- (2) In the monitor (MONI) mode, a monitor item is displayed, and about one second later its data is displayed. For details, refer to {4.2.4. Checking Operating State} and {4.2.5. List of Monitor Items}.
- (3) In the function setting (FNC) mode, parameter setting items and their values can be switched and displayed.
- (4) In the protection display mode, a protection operation item in the seven-segment display will blink to notify you. Operation will stop. For details, refer to {6.1. Protection Displays and Actions}.

■ Descriptions of the display part

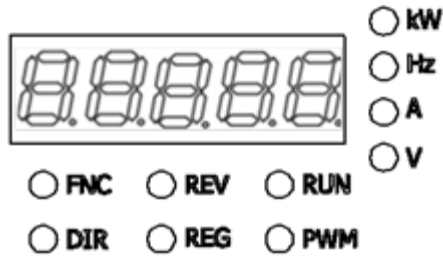

• Seven-segment display

It displays alphanumeric characters as seven-segment. For details, refer to the next section “Basic reading of the seven-segment display.”

It displays operating states, functional symbols (numbers), function selection and setting data, protection operations, and protection histories.

When only one digit of alphanumeric characters blinks, it indicates an operating digit. You can change alphanumeric characters of the operating digit by using keys [↑] or [↓].

• Unit LEDs

The LED (kW, Hz, A, or V) corresponding to the unit of numerical values in the seven-segment display turns on.

• Status LEDs

- FNC is on when the FNC mode (function setting mode) is selected.
- DIR is on when the [START]/[STOP] key on the console panel is enabled.
- REV is on when the power supply wiring is reverse phase.
- REG is on while the converter performs regenerative operation.
- RUN is on while the converter is running.
- PWM is on when the PWM sine wave mode is selected.

■ Basic reading of the seven-segment display

The table below lists a mapping of the seven-segment display to alphanumeric characters.

Since they are represented as seven-segment, in particular, you should carefully check alphabets. Some alphabets are not used to avoid a difficulty in reading them.

LED								
Alphanumeric characters	0	1	2	3	4	5 (S)	6	7
LED								
Alphanumeric characters	8	9	A	b	c	C	d	E
LED								
Alphanumeric characters	F	G	H	h	i	J	L	n (m)
LED								
Alphanumeric characters	o	P	q	r	S (5)	t	u	V
LED								
Alphanumeric characters	w	y	.(Decimal point)	_	-(Minus sign)	-1	-2	-3

■ Descriptions of the operation keys

The function of each operation key depends on the operation mode setting on the console.



Operation keys in monitor (MONI) mode

[SET] key	Changes a monitor item (forward).
[MONI/FNC] key	Switches to the function setting (FNC) mode.
[←] key	No function
[START] key	Starts the converter when "1" (Console) is set to the operation command source selection: b-03.
[↓] key	Changes a monitor item (reverse).
[↑] key	Changes a monitor item (forward).
[→] key	No function
[STOP/RESET] key	Stops the converter when it was started with the [START] key.

Operation keys in function setting (FNC) mode

[SET] key	Confirms your selection when you set a parameter setting item. Writes data of a parameter setting value.
[MONI/FNC] key	Switches to the monitor (MONI) mode.
[←] key	Shifts the operating digit by one to the left when you specify a value of a parameter setting item.
[START] key	No function
[↓] key	Changes a parameter setting item area in the alphabetical reverse order. Decreases a value of the operating digit by one when you specify a number or a value of a parameter setting item.
[↑] key	Changes a parameter setting item area in the alphabetical order. Increases a value of the operating digit by one when you specify a number or a value of a parameter setting item.
[→] key	Shifts the operating digit by one to the right.
[STOP/RESET] key	No function

Operation keys in protection display mode

[SET] key	Reads out one-point traceback data.
[MONI/FNC] key	Moves to the monitor (MONI) mode or the function setting (FNC) mode.
[←] key	No function
[START] key	
[↓] key	
[↑] key	
[→] key	Resets protection operation.
[STOP/RESET] key	

◆ Notes for each operation key

• **[MONI/FNC] key**

Switches the monitor (MONI) mode to the function setting (FNC) mode and vice versa.

The current mode is indicated by the [FNC] LED on or off.

• **[START] and [STOP/RESET] keys**

Only when you can operate the converter from the console, you can use these operation keys.

When you can operate it from the console, the [DIR] LED turns on.

• **[↑] and [↓] keys**

Each time you press these keys, the display changes one by one. Also, when you press and hold them, the display changes continuously.

■ Basic operating procedures for keys

(1) To move the operating digit

When you change various settings in the function setting (FNC) mode, a blinking digit of alphanumeric characters indicates the operating digit.

You can shift the operating digit to the right by pressing the [→] key. Shifting to the left is possible only when setting a parameter using the [←] key. If you press the [→] key while the operating digit is in the right edge of the seven-segment display, it moves to the leftmost digit or the maximum settable digit.

Likewise, if you press the [←] key while the operating digit is in the left edge of the seven-segment display or the maximum settable digit, it moves to the rightmost digit.

(2) To change numerical values

How to set a negative value in the seven-segment display on the console

Use the [→] or [←] key to move the operating digit to the leftmost one and then use the key [↑] or [↓] to change a number.

- By pressing the [↑] key

A number changes in the following order: "0" → "1" → "2" "8" → "9" → "-." After "9," a negative value is displayed.

- By pressing the [↓] key

A number changes in the following order: "0" → "-." → "9" "3" → "2" → "1." After "0," a negative value is displayed.

4.2.2. What Are Displayed at Power-on

When the converter is turned on, the following contents appear in the seven-segment display on the console:

1. The converter series name is displayed for 1.5 seconds.



The converter series name "VF66R" is displayed.

2. The converter model is displayed for 1.5 seconds.

- Two digits on the right indicate a voltage class.
- For a voltage class of 200 V, "22" is displayed, for 400 V, "44" is displayed.

Two digits on the right show "22."



3. The converter mode is displayed for 1.5 seconds.

- For the PWM sine wave mode, "VF66r" is displayed.



4. The console enters the monitor (MONI) mode, and a monitor item is displayed for one second.



"Vdc" shows a DC voltage.

5. Data of the monitor item is displayed.

- For details of monitor items and their data, refer to {4.2.5. List of Monitor Items}.



Current DC voltage is 340.0 V.

About the converter mode

- The VF66R converter provides the PWM sine wave mode and 120-degree conduction mode.

About the cooling fan

- When the converter is turned on, the cooling fan installed on it also starts at the same time.
- It behaves as follows:
 - Power-on: It operates for five minutes after power-on and then stops. However, when the converter is operated within five minutes after power-on, the cooling fan stops in one minute after the converter stops.
 - Running: It always operates.
 - Stop: After the converter stops, it operates for one minute and then stops.

4.2.3. Changing Parameter Settings

This section provides the basic operating procedures for checking and changing parameter settings required to operate the converter on the console.

- Set the console to the function setting (FNC) mode.
- Some parameters can be changed while the converter is running.
For details, refer to [5.3. Detailed Explanation of Each Parameter].

■ How to check parameter setting values

To check parameter settings of the converter, perform the following steps on the console:

For example, this section provides procedures to display a setting value of the parameter d-18 of the area d.

1. When the [FNC] LED on the console is off, press the [MONI/FNC] key.

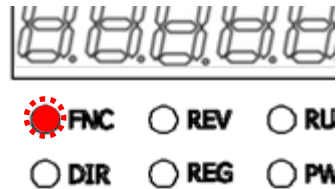

- The [FNC] LED turns on, and the console enters the function setting (FNC) mode.
- A setting item appears in the seven-segment display on the console.
For example, immediately after the converter is turned on, the first item of the basic setting area is displayed.

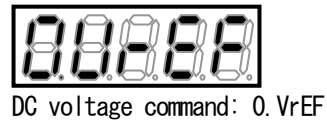

2. Press the keys [↑] or [↓] to display the first setting item "d-00" of the area d.

- The alphabet character "d" in the setting item blinks, which indicates the operating digit.



3. Press the [→] key once to blink "0" in the tens digit, and then press the keys [↑] or [↓] to change it to "1."



- As a result, "d-10" is displayed.



4. Press the [→] key once to blink "0" in the single digit, and then press the keys [↑] or [↓] to change it to "8."

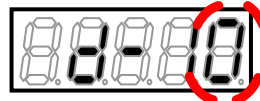

· As a result, "d-18" is displayed.

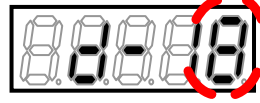

5. Press the [SET] key.

· The selection of "d-18" is confirmed, and for example its Initialize.Val "0.100" is displayed as a current setting value.
 · The display of the setting value automatically returns to that of the setting item in ten seconds.



6. Press the [MONI/FNC] key.

· The [FNC] LED turns off, and the console returns to the monitor (MONI) mode.
 · The monitor item, which was displayed before setting the parameter, is displayed for about one second. Then, its data is displayed.

Operating digit of parameter setting items

- When setting items of the area A through area S are displayed, an alphabet character or a number blinks, which indicates the operating digit.
- Each time the [→] key is pressed, the operating digit moves in the following order: alphabet character → number in the tens digit → number in the ones digit → alphabet character.
- When a number in the ones digit is changed, in some cases, a number in the tens digit is also changed. For example:
 - A value changes in the following manner: "d-09" → "d-10," "d-19" → "d-20" or "d-99" → "d-00" by pressing the [↑] key.
 - A value changes in the following manner: "d-10" → "d-09," "d-20" → "d-19" or "d-00" → "d-99" by pressing the [↓] key.

■ How to change parameter setting values

To manually set and change parameters of the converter, perform the following steps on the console:
 For example, this section provides procedures for changing the parameter d-18 of the area d from its Initialize.Val "0.100" to "0.080."

1. When the [FNC] LED on the console is off, press the [MONI/FNC] key.

· The [FNC] LED turns on, and the console enters the function setting (FNC) mode.
 · A setting item appears in the seven-segment display on the console. For example, immediately after the converter is turned on, the first item of the basic setting area is displayed.

2. Press the keys [↑] or [↓] to display the first setting item "d-00" of the area d.

· The alphabet character "d" in the setting item blinks, which indicates the operating digit.



3. Press the [→] key to blink numbers, and then press the keys [↑] or [↓] to change them to become "d-18."

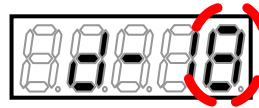

4. Press the [SET] key.

- The selection of "d-18" is confirmed, and "0.100" is displayed as a current setting value.
- The operating digit blinks. In the initial setting, the maximum digit within the Setting range (in this case "0" in the ones digit) blinks.
- The display of the setting value automatically returns to that of the setting item in ten seconds.



5. Press the keys [↑] or [↓] to change the display to "0.000."

- As a result, "0.000" is displayed.



6. Press the [→] key once and then press the keys [↑] or [↓] to change it to "8."

- As a result, "0.080" is displayed.



7. Press the [SET] key.

- The change is confirmed, and "d-18" is displayed again.
- The display of the setting value automatically returns to that of the setting item in ten seconds. Unless the [SET] key is pressed while a setting value is displayed, it is not confirmed.
- To change other parameters, repeat the procedures from the step 2.

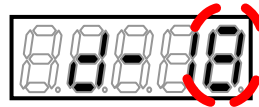

8. Press the [MONI/FNC] key.

- The [FNC] LED turns off, and the console returns to the monitor (MONI) mode.
- The monitor item, which was displayed before setting the parameter, is displayed for about one second. Then, its data is displayed.

Operating digit of parameter setting values

- The operating digit of a setting value is indicated by blinking.
 - A number from "0" to "9," a minus sign "-", or an underscore "_" (representing a blank) blinks.
- Immediately after the setting value is displayed, the maximum digit within the Setting range of that parameter blinks. Therefore, immediately after the setting value is displayed, which becomes the operating digit depends on parameters.
- For example,
 - When selecting one of selecting items "0" to "3": A number in the ones digit blinks.
 - When "150" is set in the Setting range of "0" to "150": "1" in the hundreds digit blinks.
 - When "80" is set in the Setting range of "0" to "150": An underscore blinks in the hundreds digit.
- However, note that the display of the setting value of the parameter automatically returns to that of the setting item in ten seconds.

4.2.4. Checking Operating State

The converter can display data such as AC frequency, current, and voltage on the console while it is running. A total of 25 monitor items are provided. For contents of each item, refer to {4.2.5. List of Monitor Items}. To change a monitor item, perform the following steps on the console:

1. When the [FNC] LED on the console is on, press the [MONI/FNC] key.

- The [FNC] LED turns off, and the console enters the monitor (MONI) mode.

2. The monitor item currently set is displayed.

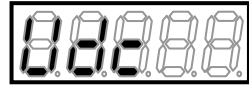

"Vdc" shows a DC voltage.

- About one second later, data of the monitor item is automatically displayed.



DC voltage shows 340.0 V.

3. Press either of the [SET] key, [↑] key, or [↓] key to return to the display of the monitor item.

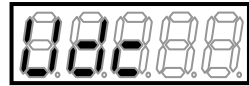

Example showing a DC voltage: Vdc

4. Press either of the [SET] key, [↑] key, or [↓] key while the monitor item is displayed.

- The next monitor item is displayed.
- About one second later, data of the monitor item is automatically displayed.
- The display order of the monitor items will differ between the [SET]/[↑] key and the [↓] key.

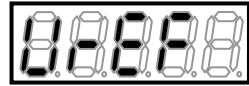

Display after pressing the [↑] key

[SET] key, [↑] key	Top to bottom in the list of monitor items
[↓] key	Bottom to top in the list of monitor items

For the types and order of monitor items, refer to the next section {4.1.5. List of Monitor Items}.

4.2.5. List of Monitor Items





The table below lists all monitor items which appear in the seven-segment display on the console in the monitor (MONI) mode.

For details of how to change the display of monitor items, refer to [4.2.4. Checking Operating State].

Press the [SET] key or [↑] key to change a monitor item from top down in the table, and the [↓] key from bottom up.

List of monitor items

Monitor contents	Display of selecting items	Unit	Description
DC voltage		V	DC voltage.
DC voltage command		V	DC voltage command.
AC current		A	Effective value of AC current.
AC voltage		V	Effective value of AC line voltage.
AC frequency		Hz	Frequency of alter.
AC power		kW	AC active power. Positive power is defined as flowing into power system.
Power supply voltage		V	Effective value of power supply line voltage.
Active current command		A	Effective value of active current command input to the AC current control part.
Reactive current command		A	Effective value of reactive current command input to the AC current control part.
Active current		A	AC active current as an effective value. Positive current is defined as flowing into power system.
Reactive current		A	AC reactive current as an effective value. Displays advance phase in the positive side and delay phase in the negative side.
Over load protection counter		%	Counter of overload (oL). When this counter reaches 100 %, a protection operation starts.

Monitor contents	Display of selecting items	Unit	Description
Input terminal check 1		-	State "ON"/"OFF" of the input terminal on the control board <VFC66R-Z>. Starting from the right digit, states of the following input terminals are displayed: [START]: Operation through the external switch [MI1] through [MI4]: Input terminals on the control board <VFC66R-Z> · Refer to another table "Displays of input and output terminal check." · "1" indicates "ON," and "0" indicates "OFF."
Input terminal check 2		-	State "ON"/"OFF" of the input terminals on the control board <VFC66R-Z> and optional board. Starting from the right digit, states of the following input terminals are displayed: [MI5]: Input terminal on the control board <VFC66R-Z> [MI6] through [MI9]: Input terminals on the optional board · Refer to another table "Displays of input and output terminal check." · "1" indicates "ON," and "0" indicates "OFF." · For terminals [MI6] through [MI9], refer to the "Operating Instructions" of the optional board.
Input terminal check 3		-	State "ON"/"OFF" of the input terminals [MI10] through [MI14] on the optional board. Starting from the right digit, states of the following input terminals are displayed: [MI10] through [MI14]: Input terminals on the optional board · Refer to another table "Displays of input and output terminal check." · "1" indicates "ON," and "0" indicates "OFF." · For terminals [MI10] through [MI14], refer to the "Operating Instructions" of the optional board.
Input terminal check 4		-	State "ON"/"OFF" of the input terminals [MI15] through [MI17] on the optional board. Starting from the right digit, states of the following input terminals are displayed: [MI15] through [MI17]: Input terminals on the optional board · Refer to another table "Displays of input and output terminal check." · "1" indicates "ON," and "0" indicates "OFF." · For terminals [MI15] through [MI17], refer to the "Operating Instructions" of the optional board.
Output terminal check 1		-	Relay status of the terminal on the control board <VFC66R-Z>. Starting from the right digit, states of the following output terminals are displayed: [52MA]: Operation contact [86A]: Protection contact [4INC]: External MC input permission [4I]: Inverter operation enable [4STA]: During MC ON

Monitor contents	Display of selecting items	Unit	Description
			<ul style="list-style-type: none"> Refer to another table "Displays of input and output terminal check." "1" indicates "ON," and "0" indicates "OFF."
Output terminal check 2		-	State "ON"/"OFF" of the output terminals [M03] through [M06] on the optional board. Starting from the right digit, states of the following output terminals are displayed: [M03] through [M06]: Output terminals on the optional board <ul style="list-style-type: none"> Refer to another table "Displays of input and output terminal check." "1" indicates "ON," and "0" indicates "OFF." For terminals [M03] through [M06], refer to the "Operating Instructions" of the optional board.

Displays of input and output terminal check

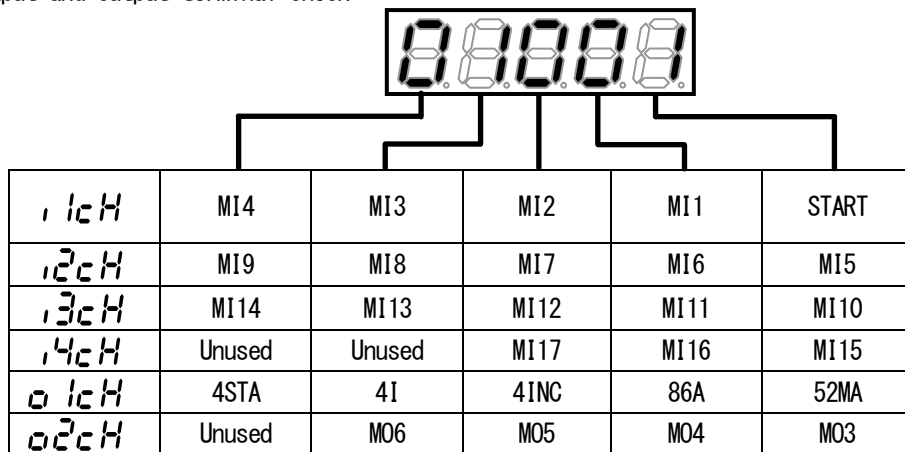

0:OFF

1:ON

Cumulative operation time		Hr	Cumulative operation time.
Timer remaining time 1		Hr	Remaining time of the main circuit capacitor timer. <ul style="list-style-type: none"> This numerical value is a guide of remaining life of the main circuit capacitor, which does not provide any guarantee. To set the cumulative operation timer (1), refer to {5.3.7. Area F}. To clear it, refer to {5.3.14. Area S}.
Timer remaining time 2		Hr	Remaining time of the cooling fan timer. <ul style="list-style-type: none"> This numerical value is a guide of remaining life of the cooling fan, which does not provide any guarantee. To set the cumulative operation timer (2), refer to {5.3.7. Area F}. To clear it, refer to {5.3.14. Area S}.

Monitor contents	Display of selecting items	Unit	Description
Main unit version		-	Version of the main unit program. · Example: VF66R-01-A1 → h01A1
PLC function version		-	Date when a sequence ladder was created. (Example: 2001-09-28 → h1928) A month value is converted as follows: 10 → A, 11 → B, 12 → C
Adjustment monitor		-	(Special monitor for special adjustment)
Protection history display		-	History of the last six protection items and the data of protection operations. · For details, refer to {6.4. How to Check Protection History}.

4.3. Operations on Console

This section provides operating procedures for the converter from the console.

When the converter can be operated from the console, the [DIR] LED turns on.

- When the [DIR] LED turns off, refer to {5.3.3. Area b}.

■ Operation flow

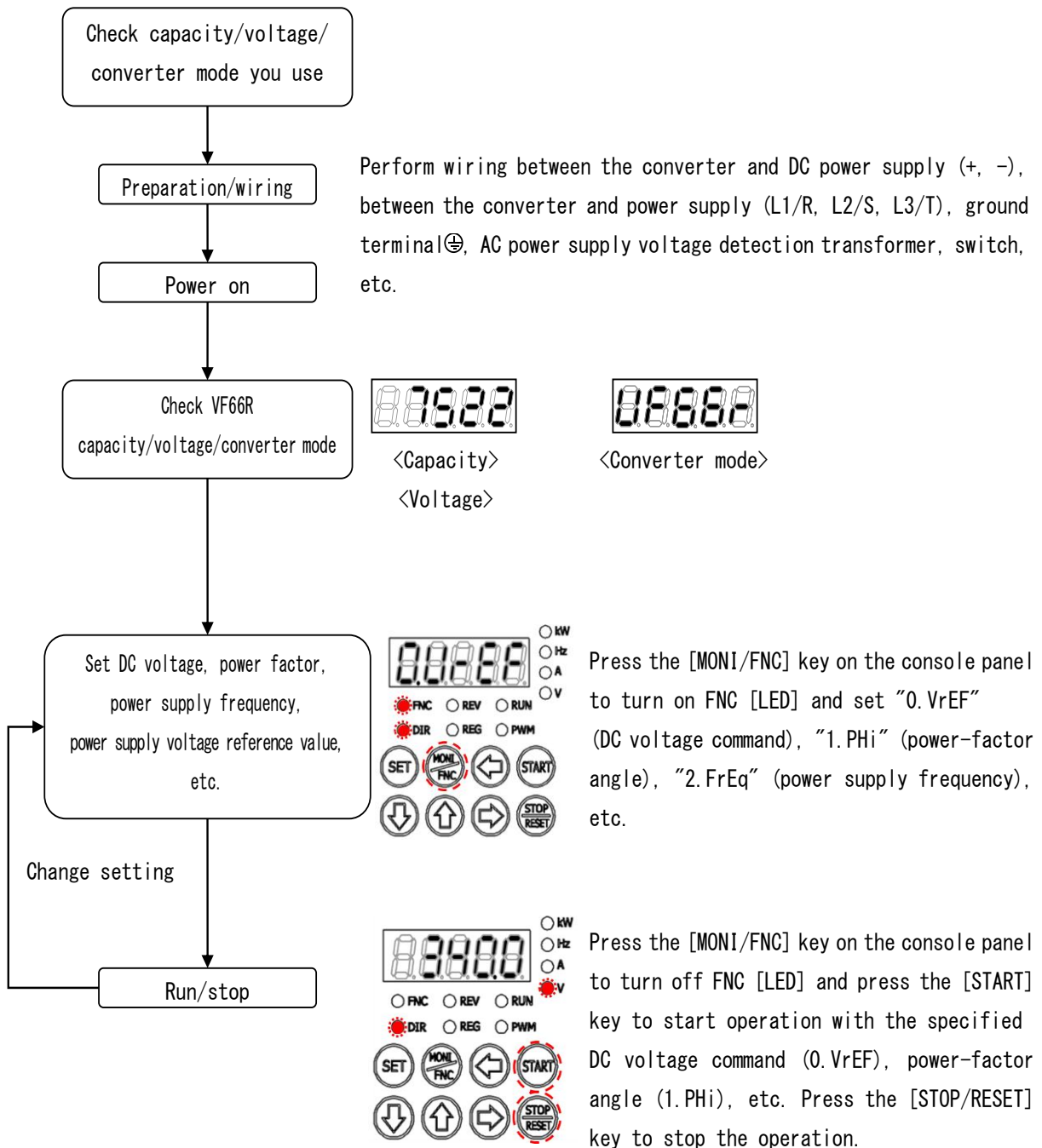

4.4. Start and Stop through External Contact

You can start and stop the converter by installing an external contact, in addition to using the [START] key and the [STOP/RESET] key on the console.

Connect the external contact to the control input terminal [START] of the terminal block TB1 on the control board <VFC66R-Z>.

This section provides a configuration and operating procedures for installing the external contact to start and stop the converter.

■ Checking jumper socket position

Check the position of the jumper socket for a jumper pin next to the terminal block TB1 on the control board <VFC66R-Z>.

- When it is positioned at [CN-SO], this indicates PS common input (source input).
- When it is positioned at [CN-SI], this indicates GND common input (sink input).

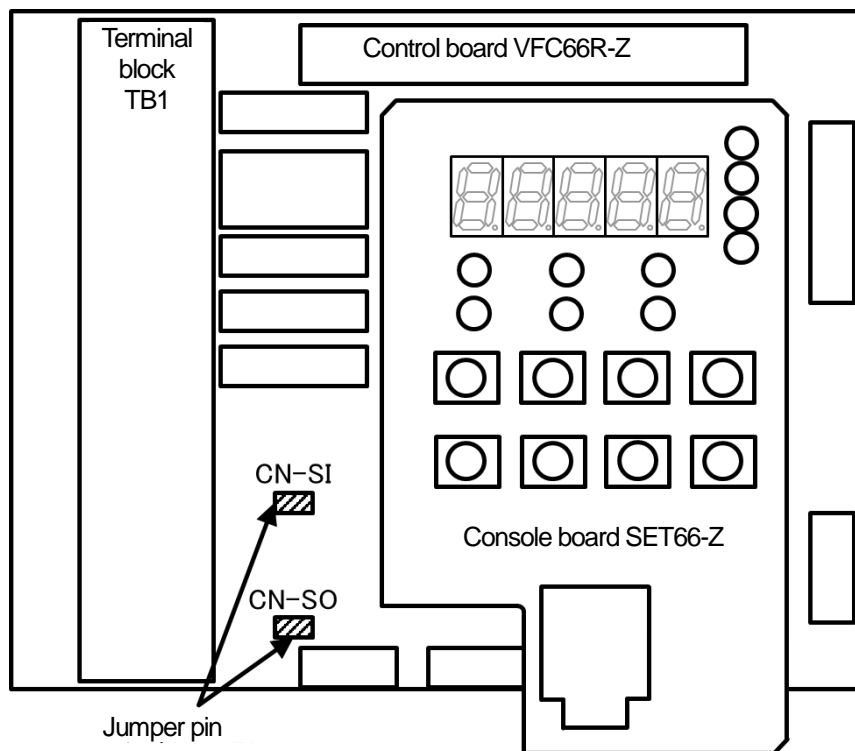

1. Turn off the converter.
2. Open the front cover.
 - For how to open the front cover, refer to {3.2. How to Open and Close Front Cover}.
 - Use the Phillips screwdriver (M4).
3. Check the position of the jumper socket for a jumper pin.
4. Close the front cover.

■ Installing the external contact and changing settings

This section provides procedures for installation and settings when the jumper socket is positioned at [CN-S0] (PS common input).

When it is positioned at [CN-S1] (GND common input), you should replace a terminal [PS] with a terminal [GND] in the procedures.

The parameter to be changed is the operation command source selection: <b-03>.

For details of how to change parameter settings, refer to {4.2.3. Changing Parameter Settings}.



Warning Installation of the external contact

- Be sure to turn off the converter before installing the external contact. Otherwise, it can result in a risk of electric shock.
- Be sure to turn off the external contact to be installed. If it is installed with it turned on, a high voltage may be output when the converter is turned on.

Prepared items

- Phillips screwdriver (M3)
- Phillips screwdriver (M4)
- External contact

1. Turn off the converter.

2. Open the front cover.

- For how to open the front cover, refer to {3.2. How to Open and Close Front Cover}.
- Use the Phillips screwdriver (M4).

3. Install the external contact between the control input terminal [START] and the terminal [PS] of the terminal block on the control board <VFC66R-Z>.

- For the terminal block and the position of terminals, refer to {3.3.1. How to Connect Converter Terminals}.
- Use the Phillips screwdriver (M3).

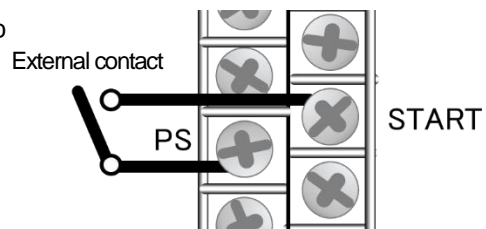

4. Close the front cover and turn on the converter.

5. When the [FNC] LED on the console is off, press the [MONI/FNC] key.

- The [FNC] LED turns on, and a setting item appears in the seven-segment display. For example, immediately after the converter is turned on, the first item of the basic setting area is displayed.

6. Press the keys [↑] or [↓] to display "b-00."



7. Press the [→] key to blink numbers, and then press the keys [↑] or [↓] to change them to <b-03>.

- For details of the operation command source selection: <b-03>, refer to {5.3.3. Area b}.



8. Press the [SET] key.

- The selection of <b-03> is confirmed, and a current setting value ("0" to "2") is displayed. In default, "0" (terminal block) is displayed.
- The display of the setting value automatically returns to that of the setting item in ten seconds. Unless a setting value is specified while it is displayed, it cannot be changed.

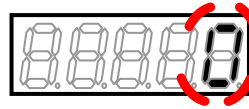

9. Press the keys [↑] or [↓] to confirm that the value is "0" (terminal block).

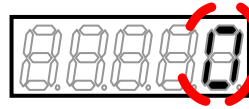

10. Press the [SET] key.

- The change is confirmed, and <b-03> is displayed again.
- The display of the setting value automatically returns to that of the setting item in ten seconds. Unless the [SET] key is pressed while a setting value is displayed, the change cannot be confirmed.



11. Press the [MONI/FNC] key.

- The [FNC] LED turns off, after a monitor item is displayed for about one second, its data appears.

12. Turn ON the external contact installed between the control input terminal [START] and the terminal [PS] to start the converter or turn it OFF to stop the converter.

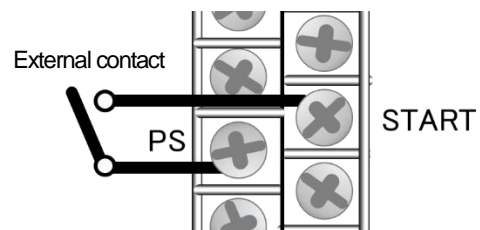

Warning Using the external contact

- Note that if the power is turned on with a signal input to the control input terminal [START] on the terminal block, the converter may suddenly start. After checking that no signal is input in the control input terminal [START], turn on the power. Otherwise, you may be injured.

Chapter 5 Explanation of Parameters

5.1. List of Parameter Areas

The converter provides parameters of a total of 13 areas: "basic setting area" and "area A" through "area S." For detailed explanation of each parameter, refer to [5.3. Detailed Explanation of Each Parameter].

List of converter setting areas

Setting area	Main contents	Description
Basic	DC voltage/power-factor angle command System frequency setting (50/60 Hz)	
Area A	Filter constant setting area	Mandatory setting area
Area b	Operation command related setting area	Rewrite protection PLC function switch Operation/DC voltage/current command source selection
Area c	Multifunction input/output related setting area	Configured in using multifunction input/output
Area d	Converter operation setting area	DC voltage command setting
Area E	Control gain setting area	AC current control/DC voltage control/AC voltage control gain settings Active/reactive current upper/lower limit setting
Area F	Protection function/traceback setting area	Related to overload protection Cumulative operation timer Traceback setting
Area J	Option setting area	Configured in using an option
Area L	Analog input/output setting area	Configured in using analog input/output Analog input/output adjustment gain and offset
Area n	Converter mode/model display area	Converter mode check Capacity/voltage class check
Area o	Special adjustment	
Area P	Special adjustment	
Area S	Converter mode selection and analog input/output adjustment area	Initialization Cumulative operation timer reset Vdc adjustment

5.2. List of Parameters

The table below lists the seven-segment displays and corresponding setting items on the console in setting parameters.

Some setting items are not used when the 120-degree conduction mode is selected. The items having ○ in the "Used in 120-degree conduction mode" column are used in the 120-degree conduction mode. The items having x are not used in the 120-degree conduction mode.

For details of each parameter, refer to [5.3. Detailed Explanation of Each Parameter].

Basic setting area

Display	Contents	Used in 120-degree conduction mode
0.VrEF	DC voltage command while selecting the DC voltage command fixed mode * Enabled when the DC voltage command fixed mode selection: <d-00> is set to ON in the PWM sine wave mode.	x
1.PHi	Power-factor angle	x
2.FrEq	Power supply frequency	x

Area A (filter constant setting area)

Display	Contents	Used in 120-degree conduction mode
A-00	AC reactor constant	x
A-01	Capacitance of filter capacitor	x

Area b (operation command related setting area)

Display	Contents	Used in 120-degree conduction mode
b-00	Setting data rewrite protection	○
b-01	PLCL function enable	○
b-02	PLCH function enable	○
b-03	Operation command source selection	○
b-04	DC voltage command source selection	x
b-05	Active current command source selection	x
b-06	Reactive current command source selection	x
b-07	Selection of restart after instantaneous power interruption	○
b-08	For special adjustment*	○

* This is for special adjustment only. Do not use it usually.

Area c (multifunction input/output related setting area)

Display	Contents	Used in 120-degree conduction mode
c-00	Multifunction input source selection	○
c-01	Multifunction input terminal (6) [MI6] function selection	○
c-02	Multifunction input terminal (7) [MI7] function selection	○
c-03	Multifunction input terminal (8) [MI8] function selection	○
c-04	Multifunction input terminal (9) [MI9] function selection	○
c-05	Multifunction input terminal (10) [MI10] function selection	○
c-06	Multifunction input terminal (11) [MI11] function selection	○
c-07	Multifunction output terminal (3) [MO3] function selection	○
c-08	Multifunction output terminal (4) [MO4] function selection	○
c-09	Integrated power setting rate	○
c-10	Output pulse width upon arrival of integrated power setting	○
c-11	Overload pre-alarm operation level setting	○
c-12	Multifunction input terminal (1) [MI1] function selection	○

Area d (converter operation setting area)

Display	Contents	Used in 120-degree conduction mode
d-00	DC voltage command fixed mode selection	x
d-01	DC voltage command gain	x
d-02	DC voltage command upper limit	x
d-03	DC voltage command lower limit	x
d-04	Soft start time	x
d-05	For special adjustment*	x
d-06	For special adjustment*	x
d-07	For special adjustment*	x
d-08	For special adjustment*	x

* This is for special adjustment only. Do not use it usually.

Area E (control gain setting area)

Display	Contents	Used in 120-degree conduction mode
E-00	AC current control proportional gain	x
E-01	AC current control differential gain	x
E-02	AC current control integral gain	x
E-03	DC voltage control basic proportional gain	x
E-04	DC voltage control maximum proportional gain	x
E-05	DC voltage control proportional gain variable ramp rate	x
E-06	DC voltage control proportional gain variable start voltage	x
E-07	DC voltage control integral gain	x
E-08	Unused	x
E-09	Unused	x
E-10	Active current command upper limit	x
E-11	Active current command lower limit	x
E-12	Reactive current command upper limit	x
E-13	Reactive current command lower limit	x
E-14	PLL proportional gain	x

Area F (protection function/traceback setting area)

Display	Contents	Used in 120-degree conduction mode
F-00	Overload protection setting	<input type="radio"/>
F-01	FCL level setting	<input type="radio"/>
F-02	Cumulative operation timer (1) (capacitor life)	<input type="radio"/>
F-03	Cumulative operation timer (2) (cooling fan life)	<input type="radio"/>
F-04	External failure (1) detection delay time	<input type="radio"/>
F-05	External failure (2) detection delay time	<input type="radio"/>
F-06	External failure (3) detection delay time	<input type="radio"/>
F-07	External failure (4) detection delay time	<input type="radio"/>
F-08	Traceback pitch	<input type="radio"/>
F-09	Traceback trigger point	<input type="radio"/>
F-10	Traceback CH1 selection	<input type="radio"/>
F-11	Traceback CH2 selection	<input type="radio"/>
F-12	Traceback CH3 selection	<input type="radio"/>
F-13	Traceback CH4 selection	<input type="radio"/>
F-14	Traceback CH5 selection	<input type="radio"/>
F-15	Traceback CH6 selection	<input type="radio"/>
F-16	Traceback CH7 selection	<input type="radio"/>
F-17	Traceback CH8 selection	<input type="radio"/>
F-18	Traceback CH9 selection	<input type="radio"/>
F-19	Traceback CH10 selection	<input type="radio"/>
F-20	Traceback CH11 selection	<input type="radio"/>
F-21	Traceback CH12 selection	<input type="radio"/>

Area J (option setting area)

Display	Contents	Used in 120-degree conduction mode
J-00	Digital_communication_option_selection	<input type="radio"/>
J-01	<ASYC66-Z> and <CC66-Z>: Option baud rate	<input type="radio"/>
J-02	<OPCN66-Z>: Option baud rate	<input type="radio"/>
J-03	<OPCN66-Z>: Number of option input frames (-> master)	<input type="radio"/>
J-04	<OPCN66-Z>: Number of option output frames (master ->)	<input type="radio"/>
J-05	<ASYC66-Z>, <OPCN66-Z>: Transmission wait time selection <CC66-Z>: CC-Link version: Number of occupied stations selection	<input type="radio"/>
J-06	<ASYC66-Z>: Communication mode selection	<input type="radio"/>
J-07	Date/Time data selection from communication	<input type="radio"/>

Area L (analog input/output setting area)

Display	Contents	Used in 120-degree conduction mode
L-00	Vdc detection gain	○
L-01	Analog output (2) selection	○
L-02	Analog output (3) selection	○
L-03	Analog output (2) gain	○
L-04	Analog output (2) offset	○
L-05	Analog output (3) gain	○
L-06	Analog output (3) offset	○
L-07	Analog input (2), (3) characteristics selection	x
L-08	For special adjustment*	x
L-09	Analog input (2) gain	x
L-10	Analog input (2) offset	x
L-11	Analog input (3) gain	x
L-12	Analog input (3) offset	x

* This is for special adjustment only. Do not use it usually.

Area n (converter mode/model display area)

Display	Contents	Used in 120-degree conduction mode
n-00	Converter mode (read-out only)	○
n-01	Capacity/voltage class (read-out only)	○
n-02	PWM carrier frequency	x
n-03, 04	For special adjustment*	○
n-05	AC voltage detection adjustment gain	○
n-06, 07	For special adjustment*	○

* This is for special adjustment only. Do not use it usually.

Area o (special adjustment area)

Display	Contents	Used in 120-degree conduction mode
o-00 through 07	For special adjustment*	○

* This is for special adjustment only. Do not use it usually.

Area P (special adjustment area)

Display	Contents	Used in 120-degree conduction mode
P-00 through 99	For special adjustment*	○

* This is for special adjustment only. Do not use it usually.

Area S (converter mode selection and analog input/output adjustment area)

Display	Contents	Used in 120-degree conduction mode
S-00	Special mode selection	○
S-01	Cumulative operation timer (1) clear	○
S-02	Cumulative operation timer (2) clear	○
S-03	Vdc adjustment	○
S-04	ROM rewrite enable switch (PLC function)	○
S-05	Analog input (2) adjustment	○
S-06	Analog output (2) adjustment	○
S-07	Analog input (3) adjustment	○
S-08	Analog output (3) adjustment	○
S-09	For special adjustment*	○
S-10	Unused	—
S-11	Monitor display selection	○

* This is for special adjustment only. Do not use it usually.

5.3. Detailed Explanation of Each Parameter

5.3.1. Basic Setting Area

In the basic setting area, the commonly used basic setting items to operate the converter are summarized. Settings such as DC voltage command and power-factor angle via the console are performed in this area. Before operating the converter, be sure to set each parameter according to the power supply specification. Of the units shown in the table, only "Hz," "A," "V" and "kW" can be displayed on the standard console. Other units cannot be displayed.

■ 0. VrEF, 1. PHi and 2. FrEq

Basic setting item

Display	Contents	Setting range (Selecting item)	Initialized data	Unit	Write during operation
0. VrEF	DC voltage command while selecting the DC voltage command fixed mode	300.0 to 358.0 (200 V class)	350.0	V	○
		600.0 to 716.0 (400 V class)	700.0		
1. PHi	Power-factor angle	-45.0 to 45.0	0.0	degree	○
2. FrEq	Power supply frequency	50/60	50	Hz	X

DC voltage setting: 0. VrEF

Set the DC voltage command for the case that the DC voltage command fixed mode selection: <d-00> is set to ON. With the DC voltage command fixed mode selection: <d-00> set to OFF, the DC voltage command variation mode is entered and thus this setting is ignored.

For the DC voltage command variation mode, refer to the description of setting items in the area d in this manual. Setting with the console can be done in increments of 0.1 V for the 400 V class unit. However, the setting is reflected in increments of 0.2 V internally. Keep this in mind.

* Caution

A DC voltage cannot be made lower than a value obtained by "effective value of AC line voltage x 1.56 (V)." When a value obtained by "effective value of AC line voltage x 1.56 (V)" becomes higher than the setting of "0. VrEF," a DC voltage command becomes a value obtained by "effective value of AC line voltage x 1.56 (V)."

Note that the maximum DC voltage command is 358 V (200 V class)/716 V (400 V class).

Power-factor angle: 1.PHi

Set the power factor for the AC side. This item is set by power-factor angle. A negative value indicates delay phase operation of current relative to the power supply voltage, whereas a positive value indicates advance phase operation. The power factor is a cosine value of the setting.

Power supply frequency: 2.FrEq

Set the frequency of the AC power supply.

5.3.2. Area A (filter constant setting area)

In the area A, set the parameters of electric constants of AC filter required for converter control. Be sure to set appropriate values before operating the converter.

■ A-00 and A-01

Electric constant of filter

Display	Contents	Setting range (Selecting item)	Initialized data	Unit	Write during operation
A-00	AC reactor constant	0.001 to 32.767	Depends on capacity	mH	x
A-01	Capacitance of filter capacitor	0.1 to 6553.5	Depends on capacity	μ F	x

AC reactor constant: A-00

Set the inductance value of the AC reactor. Set with the nominal value.

Do not change the value of the initialization data as it will affect the control performance.

Capacitance of filter capacitor capacity: A-01

Sets the capacitance of the filter capacitor. Set with the nominal value.

Do not change the value of the initialization data as it will affect the control performance.

When the control board <VFC66R-Z> is initialized, the AC reactor and filter capacitor values specified by us are automatically set.

Be sure to use the AC reactor and filter capacitor specified by Toyo Denki.

Using an unspecified AC reactor or filter capacitor may degrade the control performance.

5.3.3. Area b (operation command related setting area)

In the area b, set the parameters related to the converter operation commands.

■ b-00

Setting data protection

Display	Contents	Setting range (Selecting item)	Initialized data	Unit	Write during operation
b-00	Setting data rewrite protection	OFF: None ON: Setting data rewrite protection	OFF	-	x

Setting data rewrite protection: b-00

When b-00 is set to "ON," you cannot change setting data from the console or in other ways.

When you want to change the setting value of the parameter, select "OFF."

When you try to rewrite data with b-00 set to "ON," "PrtCt" appears in the seven-segment display on the console.

■ b-01 and b-02

PLC function selection

Display	Contents	Setting range (Selecting item)	Initialized data	Unit	Write during operation
b-01	PLCL function enable	OFF: PLC-L function disable ON: PLC-L function enable	OFF	-	x
b-02	PLCH function enable	OFF: PLC-H function disable ON: PLC-H function enable	OFF	-	x

Internal PLC function enable: b-01 and b-02

For details of this function, refer to another manual "Control Block Editor Function Manual."

■ b-03 through b-06

Command source selection

Display	Contents	Setting range (Selecting item)	Initialized data	Unit	Write during operation
b-03	Operation command source selection	0: Terminal block 1: Console 2: Digital communication option	0	-	x
b-04	DC voltage command source selection	0: Console 1: Digital communication option 2: Internal PLC	0	-	x
b-05	Active current command source selection	0: Standard (DC voltage command) 1: Digital communication option 2: Internal PLC 3: Analog input (2) terminal [AIN2] 4: Analog input (3) terminal [AIN3]	0	-	x
b-06	Reactive current command source selection	0: Standard (power-factor setting) 1: Digital communication option 2: Internal PLC 3: Analog input (2) terminal [AIN2] 4: Analog input (3) terminal [AIN3]	0	-	x

Select the command source for operation, DC voltage, active current and reactive current.

Operation command source selection: b-03

In this parameter, select the operation command source.

With "0: Terminal block" selected, an operation command is given by an input to the terminal [START].

With "1: Console" selected, an operation command is given by the [START] key on the console.

With "2: Digital communication option" selected, an operation command is given by an input of the digital communication option.

In using the PLC-L or PLC-H function, an operation command is given by an output of the PLC function regardless of the operation command source selection: b-03.

DC voltage command source selection: b-04

In this parameter, set the DC voltage command source.

With "0: Console" selected, the setting of DC voltage command fixed mode d-00 is followed.

With "1: Digital communication option" selected, digital communication option needs to be selected for the digital communication option selection: J-00.

With "2: Internal PLC" selected, the PLC-L function: b-01 or PLC-H function: b-02 needs to be set to ON.

Active current command source selection: b-05

In this parameter, set the active current command source.

With "0: Standard" selected, an active current command is determined by the DC voltage control.

With "1: Digital communication option" selected, digital communication option needs to be selected for the digital communication option selection: J-00.

With "2: Internal PLC" selected, the PLC-L function: b-01 or PLC-H function: b-02 needs to be set to ON.

With "3: Analog input (2) terminal" or "4: Analog input (3) terminal" selected, digital communication option needs to be selected for the digital communication option selection: J-00.

Reactive current command source selection: b-06

In this parameter, set the reactive current command source.

With "0: Standard" selected, a reactive current command is determined by the power-factor control.

With "1: Digital communication option" selected, digital communication option needs to be selected for the digital communication option selection: J-00.

With "2: Internal PLC" selected, the PLC-L function: b-01 or PLC-H function: b-02 needs to be set to ON.

With "3: Analog input (2) terminal" or "4: Analog input (3) terminal" selected, digital communication option needs to be selected for the digital communication option selection: J-00.

■ b-07 and b-08

Selection of restart after instantaneous power interruption during operation

Display	Contents	Setting range (Selecting item)	Initialized data	Unit	Write during operation
b-07	Selection of restart after instantaneous power interruption	ON: Enable OFF: Disable	ON	-	x
b-08	For special adjustment*	-	-	-	-

*: Do not set this item.

Selection of restart after instantaneous power interruption: b-07

Select the action taken when a drop in DC voltage or abnormality in the AC power supply occurs.

OFF: Performs the protection operation against power supply abnormality. The 86A contact is turned ON. Resetting is required to recover after the power is restored.

ON: Performs the protection operation against power supply abnormality, but the 86A contact is not turned ON. An automatic reset is performed after the power is restored.



Warning About restart after instantaneous power interruption

- When the selection of restart after instantaneous power interruption: b-07 is set to "ON: Enable", the operation is restarted automatically after the power is restored from instantaneous power interruption. Do not come close to the converter output part while instantaneous power interruption is detected. Otherwise, you may be injured.

5.3.4. Area c (multifunction input/output related setting area)

In the area c, set the parameters related to the multifunction input/output on the terminal block of the converter.

■ c-00 through c-06

Multifunction input

Display	Contents	Setting range (Selecting item)	Initialized data	Unit	Write during operation
c-00	Multifunction input source selection	0: Terminal block 1: Digital communication option	0	–	x
c-01	Multifunction input terminal (6) [MI6] function selection	0: External failure signal 1 (Protection relay 86A active) 1: External failure signal 2 (Protection relay 86A active)	0	–	x
c-02	Multifunction input terminal (7) [MI7] function selection	2: External failure signal 3 (Protection relay 86A active) 3: External failure signal 4 (Protection relay 86A active)	1	–	x
c-03	Multifunction input terminal (8) [MI8] function selection	4: External failure signal 1 (Protection relay 86A inactive) 5: External failure signal 2 (Protection relay 86A inactive)	2	–	x
c-04	Multifunction input terminal (9) [MI9] function selection	6: External failure signal 3 (Protection relay 86A inactive) 7: External failure signal 4 (Protection relay 86A inactive)	3	–	x
c-05	Multifunction input terminal (10) [MI10] function selection	8: Traceback external trigger 9: Emergency stop (B contact)	3	–	x
c-06	Multifunction input terminal (11) [MI11] function selection		3	–	x

Install and set the digital communication option to use the function of multifunction input terminal.

For how to set the digital communication option, refer to {5.3.9. Area J}.

Multifunction input source selection: c-00

With the multifunction input source: c-00 set to "1" (Digital communication option), the multifunction input is controlled by digital communication.

Multifunction input terminal (6) [MI6] through (11) [MI11] function selection: c-01 through c-06

In these parameters, set the function allocated to the multifunction input terminal (6) [MI6] through (11) [MI11].

Priority of digital communication option and internal PLC function

- When the PLC-L function usage selection: b-01 is set to "ON," any setting of the multifunction input source selection is ignored. The multifunction input terminals (6) [MI6] through (11) [MI11] on the optional board become the input relay terminals of internal PLC function.

Caution [Safety notice]

- Be sure to turn off the converter before connecting terminals.
Otherwise, it can result in a risk of electric shock.
- Close the front cover before turning on the power.
Otherwise, it can result in a risk of electric shock.
- Be sure to turn off the converter before handling the jumper.
It can result in a risk of electric shock, injury, failure, or malfunction.

■ c-07 and c-08

Multifunction output

Display	Contents	Setting range (Selecting item)	initialized data	Unit	Write during operation
c-07	Multifunction output terminal (3) [M03] function selection	0: Pulse output upon arrival of integrated power setting 1: During power failure 2: Overload pre-alarm 3: (For special adjustment)*1	0	-	x
c-08	Multifunction output terminal (4) [M04] function selection	4: Sum check error 5: In operation 6: Timer 1 elapsed 7: Timer 2 elapsed 8: Cooling fan failure	1	-	x

*1: Do not set this item.

Install and set the digital communication option to use the function of multifunction output terminal.

For how to set the digital communication option, refer to {5.3.9. Area J}.

The above "1" (During power failure) is output when the DC voltage is at a power failure level of 180 V (360 V for 400 V class) or less with normal control power supply, or the AC power supply is not established.

Multifunction output terminal (3) [M03]: c-07 and (4) [M04] function selection: c-08

In these parameters, set the function allocated to the multifunction output terminal (3) [M03] and (4) [M04].

■ c-09 through c-11

Multifunction output setting data

Display	Contents	Setting range (Selecting item)	initialized data	Unit	Write during operation
c-09	Integrated power setting rate	10.0 to 999.9	100.0	%	○
c-10	Output pulse width upon arrival of integrated power setting	1 to 1000	10	ms	○
c-11	Overload pre-alarm operation level setting	0 to 100	50	%	○

Integrated power setting rate: c-09

This is expressed in percentage using the rated power x 3 sec as 100 %.

Output pulse width upon arrival of integrated power setting: c-10

In this parameter, set the pulse width to be output when the integrated power setting is reached.

When the output power of converter reaches the reference value, ON pulse is output once, and integration starts again. Set the reference value with c-09 (Integrated power setting rate) and the output pulse width with c-10 (Output pulse width upon arrival of integrated power setting).

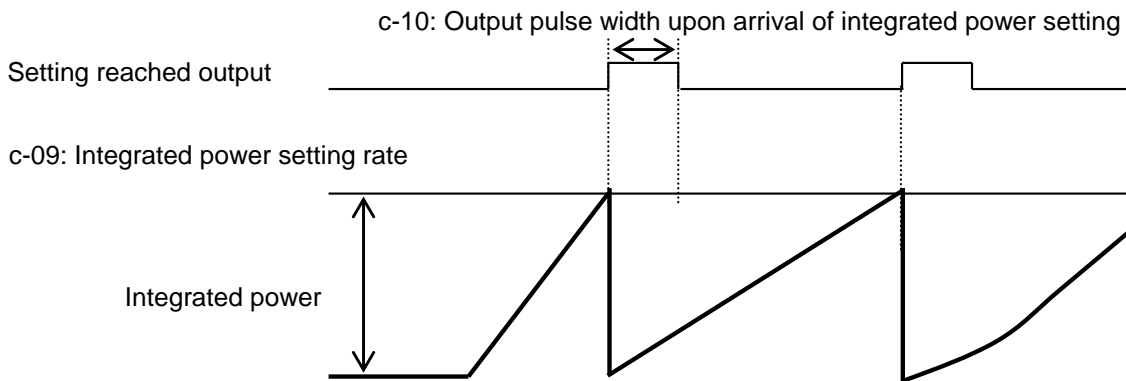

Overload pre-alarm operation level setting: c-11

When the overload counter, which starts counting when the converter is put into an overload state and causes the overload protection when 100 % is reached, exceeds the level specified by c-11 (Over load pre-alarm operation level), the output is turned on.

(For example, when c-11 is set to 50 % and output current is made 150 % as shown in the figure in the situation where overcurrent protection is activated after 60 seconds with a current of 150 %, the output is turned on when 30 seconds, which is 50 % of 60 seconds that cause the overload protection, pass.)

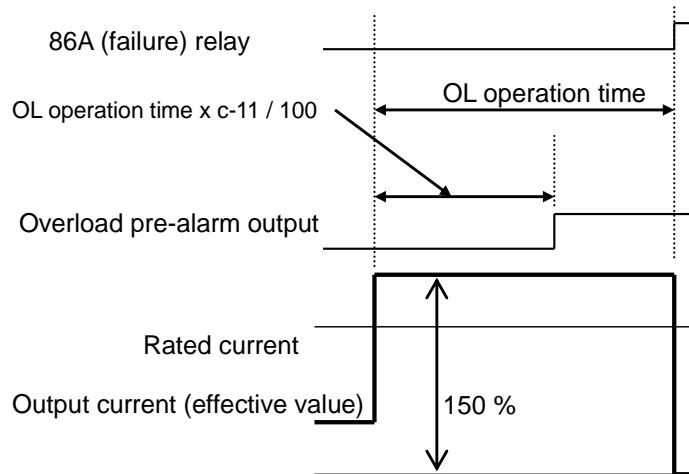

■ c-12

Multifunction input

Display	Contents	Setting range (Selecting item)	initialized data	Unit	Write during operation
c-12	Multifunction input terminal (1) [MI1] function selection	0: External failure signal 1 (Protection relay 86A active) 1: External failure signal 2 (Protection relay 86A active) 2: External failure signal 3 (Protection relay 86A active) 3: External failure signal 4 (Protection relay 86A active) 4: External failure signal 1 (Protection relay 86A inactive) 5: External failure signal 2 (Protection relay 86A inactive) 6: External failure signal 3 (Protection relay 86A inactive) 7: External failure signal 4 (Protection relay 86A inactive) 8: Traceback external trigger 9: Emergency stop (B contact)	0	-	x

Multifunction input terminal (1) [MI1] function selection: c-12

In this parameter, set the function allocated to the multifunction input terminal (1) [MI1].

5.3.5. Area d (converter operation setting area)

In the area d, set the converter operation parameters.

■ d-00 through d-08

DC voltage command related settings

Display	Contents	Setting range (Selecting item)	initialized data	Unit	Write during operation
d-00	DC voltage command fixed mode selection	0: OFF (DC voltage command variation mode) 1: ON (DC voltage command fixed mode)	0: OFF	–	x
d-01	DC voltage command gain	1.56 to 1.90	1.58	–	x
d-02	DC voltage command upper limit	300.0 to 358.0 (200 V class) 600.0 to 716.0 (400 V class)	358.0 (200 V) 716.0 (400 V)	V	x
d-03	DC voltage command lower limit		300.0 (200 V) 600.0 (400 V)	V	x
d-04	Soft start time	0.0 to 600.0	1.0	sec	x
d-05 through 08	For special adjustment*			–	x

DC voltage command fixed mode selection: d-00

Select whether to use the fixed mode for the DC voltage command.

OFF: The DC voltage command variation mode is entered, and the DC voltage command varies with the AC voltage.

In this case, the DC voltage command is determined as follows:

$$\text{DC voltage command} = \text{Effective value of AC line voltage} \times \text{DC voltage command gain: d-01}$$

ON: The DC voltage command fixed mode is entered, and the DC voltage command is fixed to the setting of the basic setting item "0.VrEF."

(Refer to the description of basic setting item 0.VrEF in this manual.)

DC voltage command gain: d-01

When the DC voltage command fixed mode selection: d-00 is set to OFF, the DC voltage command becomes a value obtained by "effective value of AC line voltage x d-01."

DC voltage command upper limit: d-02

Set the upper limit of DC voltage command for the case that the DC voltage command fixed mode selection: d-00 is set to OFF.

DC voltage command lower limit: d-03

Set the lower limit of DC voltage command for the case that the DC voltage command fixed mode selection: d-00 is set to OFF.

* Caution

A DC voltage command cannot be set lower than a value obtained by "effective value of AC line voltage x 1.56 (V)."

When a value obtained by "effective value of AC line voltage x 1.56 (V)" becomes higher than the setting of d-02 (DC voltage command upper limit), a DC voltage command becomes a value obtained by "effective value of AC line voltage x 1.56 (V)."

Note that the maximum DC voltage command is 358 V (200 V class)/716 V (400 V class).

When the DC voltage command source selection: b-03 is set to a value other than "0," the DC voltage command from the specified place takes priority.

For d-02 and d-03, setting with the console can be done in increments of 0.1 V for the 400 V class unit. However, the setting is reflected in increments of 0.2 V internally. Keep this in mind.

5.3.6. Area E (control gain setting area)

In the area E, set the parameters related to the current control gain, DC voltage control gain, current command upper/lower limit, etc.

■ E-00 through E-02

Current control gain settings

Display	Contents	Setting range (Selecting item)	Initialized data	Unit	Write during operation
E-00	AC current control proportional gain	0.0 to 9.9	5.0	-	○
E-01	AC current control differential gain	0.0 to 9.9	0.0	-	○
E-02	AC current control Integral gain	0.0 to 9.9	0.0	-	○

These are AC current control gains. Normally, do not change the initial values.

■ E-03 through E-07

Current/voltage control gain settings

Display	Contents	Setting range (Selecting item)	Initialized data	Unit	Write during operation
E-03	DC voltage control basic proportional gain	0.0 to 9.9	2.5	-	○
E-04	DC voltage control maximum proportional gain	0.0 to 9.9	7.0	-	○
E-05	DC voltage control variable ramp rate	0.0 to 9.9	3.0	-	○
E-06	DC voltage control variable start voltage	0.0 to 40.0 (200 V class)	3.0	V	○
		0.0 to 80.0 (400 V class)	6.0		
E-07	DC voltage control integral gain	0.0 to 9.9	1.0	-	○

These are DC voltage control gains. To keep both the stable characteristic in a steady state and response characteristic in a transient state, the variable proportional gain PI controller is adopted. E-03 through E-06 are used to configure the settings related to variable proportional gain, and E-07 is used to set an integral gain.

Normally, do not change the initial values.

Adjust variable structure proportional gain which changes proportional gain depending on the difference between a DC voltage command and DC voltage.

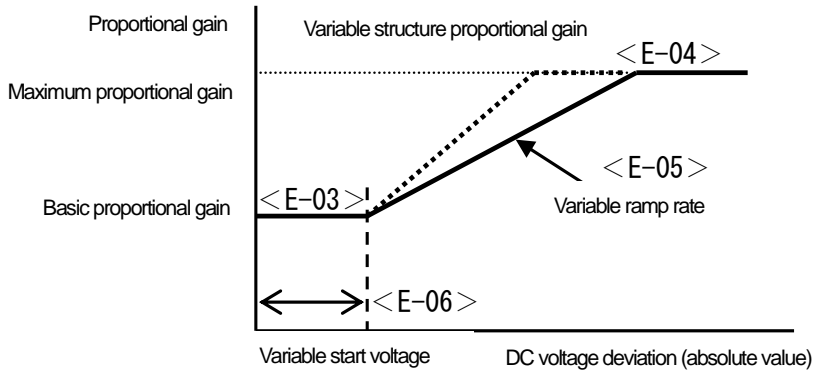

*** Caution**

For E-06, setting with the console can be done in increments of 0.1 V for the 400 V class unit. However, the setting is reflected in increments of 0.2 V internally. Keep this in mind.

■ E-08 and E-09

Display	Contents	Setting range (Selecting item)	Initialized data	Unit	Write during operation
E-08, 09	Unused	–	–	–	–

E-08 and E-09 are not used. Do not change the initial values.

■ E-10 through E-13

Current command limiter settings

Display	Contents	Setting range (Selecting item)	Initialized data	Unit	Write during operation
E-10	Active current command upper limit	-150 to 150	150	%	○
E-11	Active current command lower limit	-150 to 150	-150	%	○
E-12	Reactive current command upper limit	-150 to 150	150	%	○
E-13	Reactive current command lower limit	-150 to 150	-150	%	○

Set the ratio to the rated AC current of the converter unit.

These parameters are used to set the upper/lower limits of active/reactive current commands in operation. When a current command exceeds any of these values, it is limited to this setting value. Normally, do not change the initial values.

■ E-14

PLL gain setting

Display	Contents	Setting range (Selecting item)	Initialized data	Unit	Write during operation
E-14	PLL proportional gain	0.1 to 9.9	2.5	–	○

PLL is a phase locked loop used to make the converter internal phase and frequency follow those of the AC power supply.

The gain of the loop is adjusted according to E-14 (PLL proportional gain). Normally, do not change the initial value.

5.3.7. Area F (protection function/traceback setting area)

In the area F, set the parameters related to various protection functions and traceback functions.

■ F-00

Overload protection setting

Display	Contents	Setting range (Selecting item)	Initialized data	Unit	Write during operation
F-00	Overload protection setting	20 to 110	100	%	○

Overload protection setting: F-00

Set a reference current value of overload protection as a ratio to the rated AC current of the converter unit. When an effective value of converter output current exceeds 105 % of this reference current, this is considered as an overload situation, and the overload protection counter starts. As shown in the figure, an overload protection (OL) will be activated according to the 150 % - 60 sec characteristic curve. Normally, do not change the initial value.

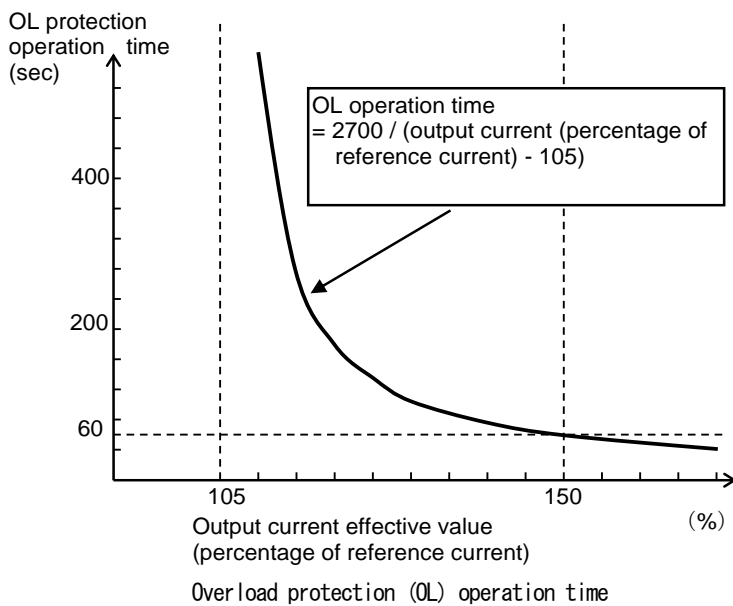

* Caution

The overload protection counter can be monitored via the console. The overload counter performs counting over time in the overload situation. When it reaches 100 %, the overload protection is activated, causing the converter to stop for protection.

oL pre-alarm function

- You can use an oL pre-alarm function to output signals when the overload counter exceeds a specified point. For details, refer to {5.3.4. Area c}.

■ F-01

FCL (high-speed current limit) level setting

Display	Contents	Setting range (Selecting item)	Initialized data	Unit	In operation Driving rewrite
F-01	FCL level setting	80 to 125	100	%	x

FCL (high-speed current limit) level setting: F-01

In this parameter, set a FCL (high-speed current limit) value. Typically, set it to 100%.

With this parameter set to 100 %, when an instantaneous current, which is 2.86 times the rated AC current of the converter unit, flows to any phase, the FCL function turns off all the outputs of converter phases to protect the converter (the converter outputs will be turned on automatically when the current drops). If turning on/off of output by the FCL function persists for ten seconds, the converter is stopped by continuous FCL protection operation.

■ F-02 and F-03

Cumulative operation timer setting

Display	Contents	Setting range (Selecting item)	Initialized data	Unit	Write during operation
F-02	Cumulative operation timer (1) (main circuit capacitor life)	0 to 65535	See following table	Hr	x
F-03	Cumulative operation timer (2) (cooling fan life)	0 to 65535	See following table	Hr	x

Cumulative operation timer (1): F-02 and Cumulative operation timer (2): F-03

For monitor items and replacing the cooling fan, refer to {7.2. Main Circuit Capacitor/Cooling Fan Replacement Timing} and {7.3. How to Replace Cooling Fan}.

Table: Factory initialized data of F-02 and F03

Converter model	F-02 initialized data	F-03 initialized data	Converter model	F-02 initialized data	F-03 initialized data
7522	43800	21900	7544	43800	21900
9022			11044		
15022			16044		
18022			20044		
			25044		
			31544		
			40044		
			50044		
			60044		
			75044		
	100044				

■ F-04 through F-07

External failure detection delay time setting

Display	Contents	Setting range (Selecting item)	Initialized data	Unit	Write during operation
F-04	External failure 1 detection delay time	0.0 to 30.0	0.0	sec	○
F-05	External failure 2 detection delay time	0.0 to 30.0	0.0	sec	○
F-06	External failure 3 detection delay time	0.0 to 30.0	0.0	sec	○
F-07	External failure 4 detection delay time	0.0 to 30.0	0.0	sec	○

External failure 1 through 4 detection delay time: F-04 through F-07

Time required to detect external failure signals can be delayed during the amount of time specified in the External failure 1 through 4 detection delay time: F-04 through F-07.

These are used to adjust detection sensitivity of external failure signals.

■ F-08 through F-21

External failure detection delay time setting

Display	Contents	Setting range (Selecting item)	Initialized data	Unit	Write during operation
F-08	Traceback_pitch	1 to 100	1	msec	○
F-09	Traceback trigger point	1 to 99	80	-	○
F-10	Traceback CH1 selection	0 to 12	0	-	○
F-11	Traceback CH2 selection		0	-	○
F-12	Traceback CH3 selection		0	-	○
F-13	Traceback CH4 selection		0	-	○
F-14	Traceback CH5 selection		0	-	○
F-15	Traceback CH6 selection		0	-	○
F-16	Traceback CH7 selection		0	-	○
F-17	Traceback CH8 selection		0	-	○
F-18	Traceback CH9 selection		0	-	○
F-19	Traceback CH10 selection		0	-	○
F-20	Traceback CH11 selection		0	-	○
F-21	Traceback CH12 selection		0	-	○

VF66R incorporates a traceback function which can store, read out, and analyze control data such as current and voltage of protection operations to rapidly restore it. For data stored by the traceback function, you can specify current and voltage defined as initial values as well as output from each internal PLC when the PLC function is used.

Traceback pitch: F-08

Set an interval of traceback.

Traceback trigger point: F-09

Set a traceback trigger point.

Traceback CH1 through CH12 selection: F-10 through F-21

Select whether to use the converter internal data for each channel of traceback.

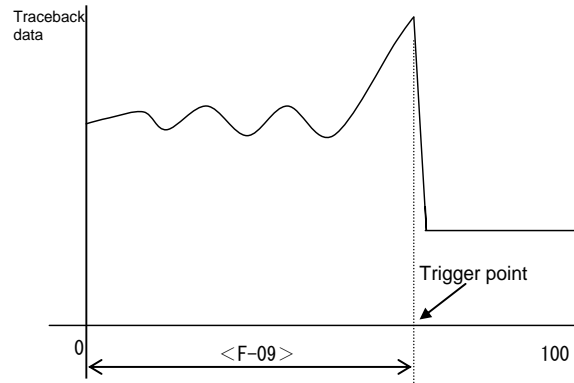

Traceback point setting

*** Caution**

The traceback pitch and traceback point should be set before traceback data of protection operations and others is captured.

F-10 through 21 settings	0	Dimension	1 to 12
	Recorded data		Recorded data
ch1	U phase current	2357digit = Unit rated AC current	PLC output RAM (1 through 12) (Settings of F-10 through 21 become the selection of output RAM.)
ch2	V phase current		
ch3	W phase current		
ch4	DC voltage	10digit/V(200V) 5digit/V(400V)	
ch5	U phase power supply voltage	114digit/V(200V) 57digit/V(400V)	
ch6	V phase power supply voltage		
ch7	W phase power supply voltage		
ch8	U phase control voltage	67digit/V(200V)	
ch9	V phase control voltage	33digit/V(400V)	
ch10	W phase control voltage		
ch11	DC voltage command	10 digit/V (200/400 V)	
ch12	Active current command	9700digit = Unit rated AC current	

5.3.8. Area G (special adjustment area)

Do not set the area G since it is provided for special adjustment.

5.3.9. Area J (setting area for digital communication options)

In the area J, you can set parameters of converter digital communication options.

■ J-00

Digital_communication_option_selection

Display	Contents	Setting range (Selecting item)	initialized data	Unit	Write during operation
J-00	Digital communication option selection	0: OFF 1: <OPCN66-Z> 2: <ASYC66-Z> 3: (For expanded options)* 4: (For expanded options)* 5: <I066-Z> 6: (For expanded options)* 7: <CC66-Z>	0	-	x

*: Do not set this item.

Option selection: J-00

In this parameter, set a value corresponding to the installed option.

When a value other than "0" is selected without an option connected, an optional error occurs causing the converter to stop for protection.

■ J-01 through J-08

Digital communication option settings

Display	Contents	Setting range (Selecting item)	initialized data	Unit	Write during operation
J-01	<ASYC66-Z> <CC66-Z> Option baud rate	Using <ASYC66-Z> 0: 1200 bps 1: 2400 bps 2: 4800 bps 3: 9600 bps 4: 19200 bps 5: 38400 bps Using <CC66-Z> 0: 156 kbps 1: 625 kbps 2: 2.5 Mbps 3: 5 Mbps 4: 10 Mbps 5: 10 Mbps	4	-	○
J-02	<OPCN66-Z> Option baud rate	0: 125 kbps 1: 250 kbps 2: 500 kbps 3: 1 Mbps 4: (For special adjustment)*	3	-	x
J-03	<OPCN66-Z> Number of option input frames (-> master)	3 to 19	14	-	x
J-04	<OPCN66-Z> Number of option output frames (master ->)	2 to 12	6	-	x
J-05	<ASYC66-Z> <OPCN66-Z> Transmission wait time selection <CC66-Z> CC-Link version number of occupied stations selection	Using <ASYC66-Z> 0: 0 ms 1: 5 ms 2: 10 ms 3: 20 ms 4: 40 ms 5: 60 ms 6: 100 ms Using <OPCN66-Z> Baud rate (J-02) (125 k/250 k/200 k/1 Mbps) 0: 200/200/200/200 μs 1: 200/200/200/200 μs 2: 200/200/200/200 μs 3: 200/200/200/200 μs 4: 200/150/150/150 μs 5: 200/100/100/100 μs 6: 200/100/50/50 μs Using <CC66-Z> Version/number of occupied stations 0: 1.1/1 1: 1.1/2 2: 1.1/3 3: 1.1/4 4: 2.0 (double)/1 5: 2.0 (4 times)/1 6: 2.0 (8 times)/1	0	-	x
J-06	<ASYC66-Z> Communication mode selection	0: Standard communication mode	0	-	x
J-07	Date/Time data selection from communication	0: Without date/time data 1: With date/time data	0	-	x

For details, refer to the manuals of digital communication options.

5.3.10. Area L (analog input/output setting area)

In the area L, you can set parameters such as analog input/output gain and offset of the converter.

■ L-00

Display	Contents	Setting range (Selecting item)	Initialized data	Unit	Write during operation
L-00	Vdc_detection_gain	80.0 to 120.0	100.0	%	x

DC voltage detection gain: L-00

This parameter indicates detection adjustment gain of DC voltage detected by the converter.

By inputting the voltage between the DC terminals [+] and [-] during converter initialization, this DC voltage detection gain is back calculated and the resulted value is set to this parameter. Normally, use it without changing the initialized value.

When the gate board <GAC66>, etc. is replaced, an error may occur between "Vdc" display on the console and the actual voltage between the DC terminals [+] and [-]. In this case, to adjust DC voltage detection gain without initializing memory, refer to {5.4.3. DC Voltage Detection Gain Adjustment}.

Also, when the control board <VFC66R-Z> is replaced, refer to {5.4.3. DC Voltage Detection Gain Adjustment} and perform adjustment.

■ L-01 and L-02

Analog output selection

Display	Contents	Setting range (Selecting item)	Initialized data	Unit	Write during operation
L-01	Analog output (2) selection	0: AC voltage 1: AC current 2: AC frequency 3: AC power 4: DC voltage	1	-	x
L-02	Analog output (3) selection	5: Internal PLC output 6: Calibration 7: (For special adjustment)* 8: (For special adjustment)*	0	-	x

*: Do not set this item.

Analog output selection: L-01 and L-02

With these parameters, select the analog output between the analog output (2) terminal [AOT2]/analog output (3) terminal [AOT3] and the terminal [G-OT]. Install an optional board to use the analog output.

Analog outputs selected by L-01 and L-02

	Selection items	Output voltage		Selection items	Output voltage
0	AC voltage	7.5/200 V (200 V class) 7.5/400 V (400 V class)	4	DC voltage	7.5/300 V (200 V class) 7.5/600 V (400 V class)
1	AC current	5 V/rated converter current (Indicates an effective value)	5	Built-in PLC output	5 V/20000 (100 %)
2	AC frequency	5 V/50 Hz	6	Calibration	Output 5 V
3	AC power	5 V/rated power*			

*: The rated power is obtained by $\sqrt{3}$ x voltage x rated unit current.

■ L-03 through L-06 and L-09 through L-12

Analog input/output gain and offset adjustment

Display	Contents	Setting range (Selecting item)	Initialized data	Unit	Write during operation
L-03	Analog_output (2) gain	50.0 to 150.0	100.0	%	○
L-04	Analog_output (2) offset	-50.0 to 50.0	0.0	%	○
L-05	Analog_output (3) gain	50.0 to 150.0	100.0	%	○
L-06	Analog_output (3) offset	-50.0 to 50.0	0.0	%	○
L-09	Analog_input (2) gain	50.00 to 150.00	100.00	%	○
L-10	Analog_input (2) offset	-50.00 to 50.00	0.00	%	○
L-11	Analog_input (3) gain	50.00 to 150.00	100.00	%	○
L-12	Analog_input (3) offset	-50.00 to 50.00	0.00	%	○

L-03 through L-06, and L-09 through L-12 are setting areas for adjusting analog input/output gain and offset. These values are automatically set when analog output adjustment for the area S or analog input adjustment is performed. Therefore, normally you do not have to set them manually.

■ L-07 and L-08

Analog input characteristics selection

Display	Contents	Setting range (Selecting item)	Initialized data	Unit	Write during operation
L-07	Analog input (2) (3) characteristics selection	0: 0 to ± 10 V	0	-	x
L-08	For special adjustment*	-	-	-	-

*: Do not set this item.

Analog input characteristics selection: L-07

With these parameters, select the characteristics of the signal input to the analog input terminal. For details, refer to the manual of digital communication option.

5.3.11. Area n (converter mode/model display area)

The area n is used to read out the converter mode and model.

■ n-00 through n-04

Converter mode and model check

Display	Contents	Setting range (Selecting item)	Initialized data	Unit	Write during operation
n-00	Converter mode	VF66r: PWM sine wave mode Vr120: 120-degree conduction mode	VF66r	-	x
n-01	Converter model	7522 to 18022 7544 to 100044	Value corresponding to the converter rating	-	x
n-02	PWM carrier frequency	5.0 to 7.0	6.0	kHz	x
n-03	For special adjustment*	-	-	-	-
n-04	For special adjustment*	-	-	-	-

*: Do not set this item.

Converter mode: n-00 and Converter model: n-01

By reading out these settings, you can check the converter mode and model.

This parameter is for read-out only. You cannot use it for writing. Writing is always prohibited.

When changing the converter model specified for the control board <VFC66R-Z> due to replacement of spare parts, etc., you should first initialize memory.

For how to initialize memory, refer to {8.3. How to Initialize Converter Main Unit}.

PWM carrier frequency: n-02

This indicates a PWM carrier frequency. Normally, do not change the initial value.

For special adjustment: n-03 and n-04

Do not set these parameters since they are provided for special adjustment.

■ n-05 and n-06

Voltage detection adjustment gain

Display	Contents	Setting range (Selecting item)	Initialized data	Unit	Write during operation
n-05	AC voltage detection adjustment gain	90.0 to 110.0	100.0	%	○
n-06	For special adjustment*	–	–	–	–

*: Do not set this item.

AC voltage detection adjustment gain: n-05

With this parameter, adjust the gain of converter AC voltage detection. Set this parameter so that the voltage applied to the AC voltage detection transformer matches the "VAc" monitor value.

5.3.12. Area o (special adjustment area)

Do not set the area o since it is provided for special adjustment.

5.3.13. Area P (special adjustment area)

Do not set the area P since it is provided for special adjustment.

5.3.14. Area S (converter mode selection and analog input/output adjustment area)

In the area S, set the parameters related to special functions such as converter initialization and data transfer, automatic adjustment of analog input/output gain and offset, etc.

To use parameters of the area S, you should input a password "1040."

■ S-00

Special mode selection

Display	Contents	Setting range (Selecting item)	Initialized data	Unit	Write during operation
S-00	Special mode selection	1: Initialize the converter 2: (For special adjustment) 3: Clear protections 99: (For special adjustment) 101: Data transfer to <SET66R-Z> 102: Copy data from <SET66R-Z> (Without area A) 103: Copy data from <SET66R-Z> (With area A) 104: Compare data with <SET66R-Z>	-	-	○

Special mode selection: S-00

Setting items of S-00 are described below.

In these items, set or change various functions of the converter.

◆ Setting items of the special mode selection: S-00

Setting item	Descriptions
1	For details of initialization, refer to {8.3. How to Initialize Converter Main Unit}.
2	This is for special adjustment only. Do not use it usually.
3	For details of clearing protections, refer to {5.4.1. How to Clear Protections}.
99	This is for special adjustment only. Do not use it usually.
101	For details of data transfer to <SET66R-Z>, refer to {5.4.2. Data Transfer from/to External Console Option}.
102	For details of data copy (without area A) from <SET66R-Z>, refer to {5.4.2. Data Transfer from/to External Console Option}.
103	For details of data copy (with area A) from <SET66R-Z>, refer to {5.4.2. Data Transfer from/to External Console Option}.
104	For details of comparing data with <SET66R-Z>, refer to {5.4.2. Data Transfer from/to External Console Option}.

When you input a different number from "1040" to S-00 and press the [SET] key, "P-Err" (password error) is displayed.

■ S-01 and S-02

Cumulative timer clear setting

Display	Contents	Setting range (Selecting item)	initialized data	Unit	Write during operation
S-01	Cumulative operation timer(1) clear	1: Clear the cumulative operation timer(1)	-	-	○
S-02	Cumulative operation timer(2) clear	1: Clear the cumulative operation timer(2)	-	-	○

Cumulative operation timer (1) clear: S-01

When "1" is set to S-01 after inputting a password "1040," a count value of the cumulative operation timer (1) can be cleared.

Cumulative operation timer (2) clear: S-02

When "1" is set to S-02 after inputting a password "1040," a count value of the cumulative operation timer (2) can be cleared.

■ S-03 through S-17

DC voltage adjustment and analog gain/offset automatic adjustment

Display	Contents	Setting range (Selecting item)	Initialized data	Unit	Write during operation
S-03	Vdc adjustment	DC voltage detection value	-	V	x
S-04	For special adjustment*	-	-	-	x
S-05	Analog input(2) adjustment	1: Offset adjustment Input a value 1000 times voltage (V) : Gain adjustment	-	-	x
S-06	Analog output(2) adjustment	1: Offset adjustment 2: Gain adjustment	-	-	x
S-07	Analog input(3) adjustment	1: Offset adjustment Input a value 1000 times voltage (V) : Gain adjustment	-	-	x
S-08	Analog output(3) adjustment	1: Offset adjustment 2: Gain adjustment	-	-	x
S-09	For special adjustment*	-	-	-	x
S-10	For special adjustment*	-	-	-	x
S-11	Monitor display selection	0: Disable monitor display 1: Enable monitor display	0: Disable monitor display	-	○

*: Do not set this item.

For operating procedures listed below, refer to {5.4. Operation Using S Area Parameters}.

- How to adjust DC voltage with S-03
- How to automatically adjust analog input/output gain, etc. with S-05 through S-08.

5.4. Operation Using S Area Parameters

5.4.1. How to Clear Protections

To clear protections such as data displayed in the monitor item (Protection history display trbLE), perform the following steps on the console:

These steps can be performed even while the converter is running.

Use "3" (Clear protections) of the Special_mode_selection S-00.

For details of the Special_mode_selection S-00, refer to {5.3.14. Area S}. For details of how to change parameter settings, refer to {4.2.3. Changing Parameter Settings}.

1. When the [FNC] LED on the console is off, press the [MONI/FNC] key.

- The [FNC] LED turns on, and a setting item appears in the seven-segment display. For example, immediately after the converter is turned on, the first item of the basic setting area is displayed.

2. Press the keys [↑] or [↓] to display "S-00."



3. Press the [SET] key.

- "0" is displayed on the extreme right, and the underscore blinks on the extreme left.

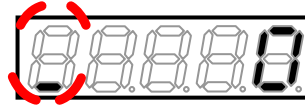

4. Press the [→] key to blink required digits, and then press the keys [↑] or [↓] to specify "1040."



5. Press the [SET] key.

- The password input is confirmed, and the screen returns to "S-00" display.
- When a different number from "1040" is input, "P-Err" indicating an error is displayed. In this case, press the keys [↑] or [↓] to return to "S-00." Follow the procedures again from the step 3.



Display indicating a password error

6. Press the [SET] key.

- Again, "0" is displayed on the extreme right, and the underscore blinks on the extreme left.



7. Press the [→] key to blink a required digit, and then press the keys [↑] or [↓] to change the number to "3" (Clear protections).

- The display of the setting value automatically returns to that of the setting item in ten seconds. Unless a setting value is specified while it is displayed, it cannot be changed.

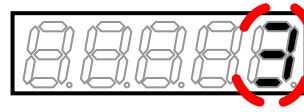

8. Press the [SET] key.

- The display of the setting value automatically returns to that of the setting item in ten seconds. Unless the [SET] key is pressed while a setting value is displayed, it is not confirmed.
- Clear of data such as protection histories is confirmed, "cLEAr" is displayed for about 1.5 seconds, and then "S-00" is displayed again.

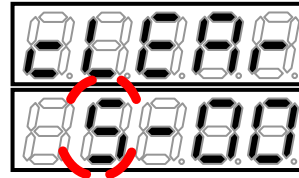

9. Press the [MONI/FNC] key.

- The [FNC] LED turns off, after a monitor item is displayed for about one second, its data appears.

5.4.2. Data Transfer from/to External Console Option

This section describes how to exchange data between the main unit and external console option <SET66R-Z> which is connected to the converter main unit.



Warning Installation of the external console option

- Before installing <SET66R-Z>, be sure to take any measures against static electricity. Otherwise, circuits inside the converter may be damaged.

When the external console option is connected

- When <SET66R-Z> has been connected to the converter main unit, the console on the main unit cannot be used. Also, when the main unit cannot communicate with <SET66R-Z>, <SET66R-Z> does not react. Check connections between them and others.

■ Transferring setting data to the external console option <SET66R-Z>

To transfer setting data of the converter main unit to the external console option <SET66R-Z>, perform the following steps:

Use "101" of the Special mode selection <S-00>.

For details of the Special mode selection <S-00>, refer to [5.3.14. Area S]. For details of how to change parameter settings, refer to [4.2.3. Changing Parameter Settings].

1. Connect the console of the converter main unit to <SET66R-Z>.

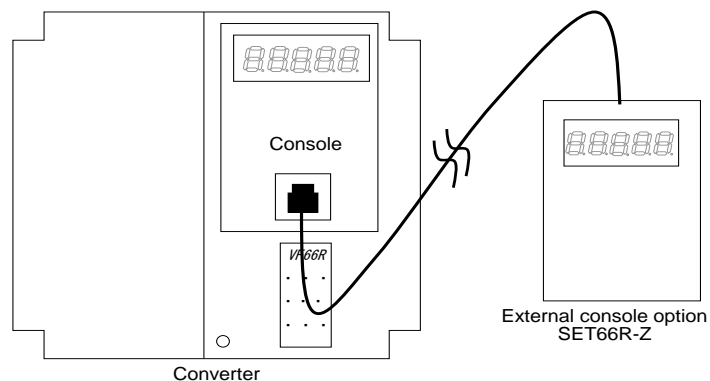

2. When the [FNC] LED on the console is off, press the [MONI/FNC] key.

- The [FNC] LED turns on, and a setting item appears in the seven-segment display. For example, immediately after the converter is turned on, the first item of the basic setting area is displayed.

3. Press the keys [↑] or [↓] to display "S-00."



4. Press the [SET] key.

- "0" is displayed on the extreme right, and the underscore blinks on the extreme left.



5. Press the [→] key to blink required digits, and then press the keys [↑] or [↓] to specify "1040."



6. Press the [SET] key.

- The password input is confirmed, and the screen returns to "S-00" display.
- When a different number from "1040" is input, "P-Err" indicating an error is displayed.

In this case, press the keys [↑] or [↓] to return to "S-00." Follow the procedures again from the step 4.



Display indicating a password error

7. Press the [SET] key.

- Again, "0" is displayed on the extreme right, and the underscore blinks on the extreme left.

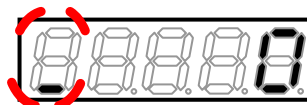

8. Press the [→] key to blink a required digit, and then press the keys [↑] or [↓] to change the number to "101."

- The display of the setting value automatically returns to that of the setting item in ten seconds. Unless a setting value is specified while it is displayed, it cannot be changed.

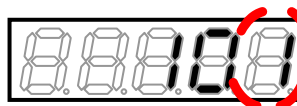

9. Press the [SET] key.

- The display of the setting value automatically returns to that of the setting item in ten seconds. Unless the [SET] key is pressed while a setting value is displayed, it is not confirmed.
- The change is confirmed, and "VtoS" and "SurE" blink alternately.

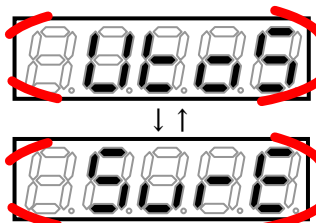

10. Press the [SET] key.

- The setting is confirmed, and "VtoS" is displayed.



Data is being transferred

- Data is transferred from the converter main unit to <SET66R-Z>. When it has been completed successfully, "End" is displayed.
- When communication between the main unit and <SET66R-Z> fails during the transfer process, transfer is interrupted.



Data transfer has been completed

- (1) Interrupted with the setting block displayed
- (2) Interrupted ten seconds after blinking "rErr"

In either case, the setting block is displayed after interruption and then the monitor item display returns. Perform again the procedures from the first step.



Error indication

- In a few seconds, the setting block is displayed, and then a monitor item is displayed.

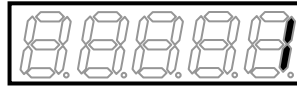

■ Copying setting data from <SET66R-Z> to the converter main unit (the area A is not copied)
 To transfer setting data of <SET66R-Z> to the converter main unit, perform the following steps:
 However, setting data of the area A is not copied.
 To change a converter model, use this way.
 Use "102" of the Special mode selection <S-00>.

For details of the special mode selection, refer to {5.3.14. Area S}. For details of how to change parameter settings, refer to {4.2.3. Changing Parameter Settings}.

When the external console option is connected

● When <SET66R-Z> has been connected to the converter main unit, the console on the main unit cannot be used.
 Also, when the main unit cannot communicate with <SET66R-Z>, <SET66R-Z> does not react. Check connections between them and others.

1. Connect the console of the converter main unit to <SET66R-Z>.

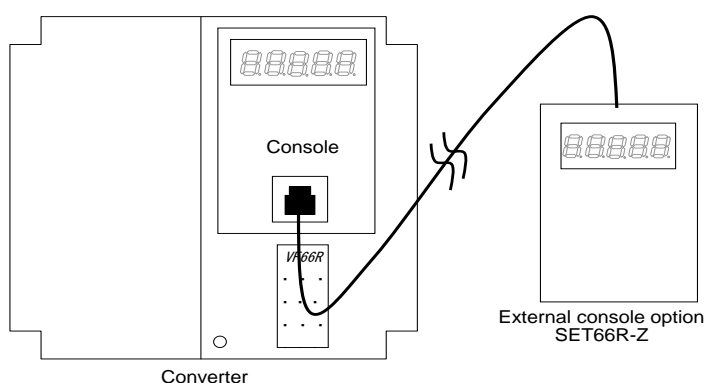

2. When the [FNC] LED on the console is off, press the [MONI/FNC] key.

· The [FNC] LED turns on, and a setting item appears in the seven-segment display. For example, immediately after the converter is turned on, the first item of the basic setting area is displayed.

3. Press the keys [↑] or [↓] to display "S-00."

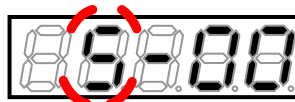

4. Press the [SET] key.

· "0" is displayed on the extreme right, and the underscore blinks on the extreme left.



5. Press the [→] key to blink required digits, and then press the keys [↑] or [↓] to specify numbers to become "1040."



6. Press the [SET] key.

- The password input is confirmed, and the screen returns to "S-00" display.
- When a different number from "1040" is input, "P-Err" indicating an error is displayed.

In this case, press the keys [↑] or [↓] to return to "S-00." Follow the procedures again from the step 4.

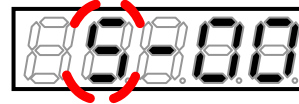

Display indicating a password error

7. Press the [SET] key.

- Again, "0" is displayed on the extreme right, and the underscore blinks on the extreme left.



8. Press the [→] key to blink a required digit, and then press the keys [↑] or [↓] to change the number to "102."

- The display of the setting value automatically returns to that of the setting item in ten seconds. Unless a setting value is specified while it is displayed, it cannot be changed.



9. Press the [SET] key.

- The display of the setting value automatically returns to that of the setting item in ten seconds. Unless the [SET] key is pressed while a setting value is displayed, it is not confirmed.
- The change is confirmed, and "StoV1" and "SurE" blink alternately.

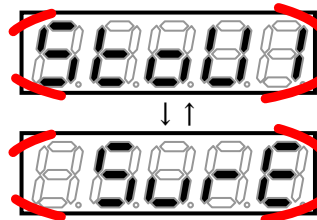

10. Press the [SET] key.

- The setting is confirmed, and "StoV1" is displayed.



Data is being transferred

- When the version of the converter main unit is different from the software version number of <SET66R-Z>, "VErr" blinks.
- Press the [STOP/RESET] key to interrupt copying data. Press the [SET] key to continue to copy data.



- Data is transferred from the converter main unit to <SET66R-Z>. When it has been completed successfully, "End" is displayed.
- When communication between the main unit and <SET66EX-Z> is disconnected during transfer, transfer is interrupted.

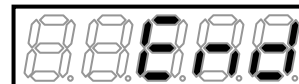

Data transfer has been completed

- (1) Interrupted with the setting block displayed
 - (2) Interrupted ten seconds after blinking "rErr"
- In either case, the setting block is displayed after interruption and then the monitor item display returns. Perform again the procedures from the first step.



Error indication

- Five seconds later, the converter series name is displayed, and then contents similar to what are displayed at power-on are displayed. Refer to {4.1.2. What Are Displayed at Power-on}.



■ Copying setting data from <SET66R-Z> (the area A is also copied)

To transfer setting data of <SET66R-Z> to the converter main unit, perform the following steps:

Setting data of the area A is also copied.

When the converter model is the same, use this way.

Use "103" of the Special mode selection <S-00>.

For details of the special mode selection, refer to {5.3.14. Area S}. For details of how to change parameter settings, refer to {4.2.3. Changing Parameter Settings}.

When the external console option is connected

- When <SET66R-Z> has been connected to the converter main unit, the console on the main unit cannot be used. Also, when the main unit cannot communicate with <SET66R-Z>, <SET66R-Z> does not react. Check connections between them and others.

1. Connect the console of the converter main unit to <SET66R-Z>.

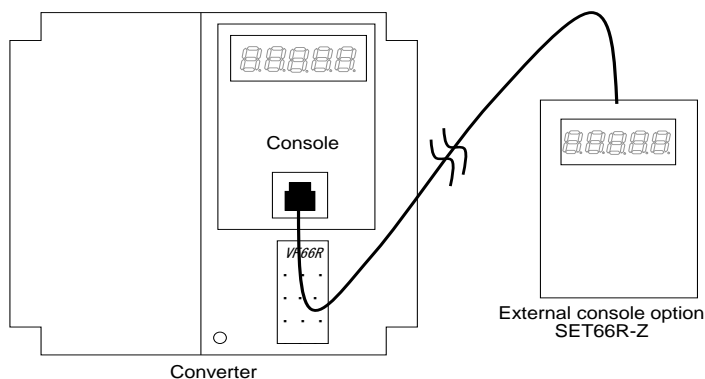

2. When the [FNC] LED on the console is off, press the [MONI/FNC] key.

- The [FNC] LED turns on, and a setting item appears in the seven-segment display. For example, immediately after the converter is turned on, the first item of the basic setting area is displayed.

3. Press the keys [↑] or [↓] to display "S-00."



4. Press the [SET] key.

- "0" is displayed on the extreme right, and the underscore blinks on the extreme left.

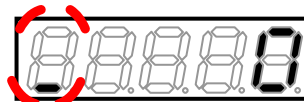

5. Press the [→] key to blink required digits, and then press the keys [↑] or [↓] to specify numbers to become "1040."



6. Press the [SET] key.

- The password input is confirmed, and the screen returns to "S-00" display.
- When a different number from "1040" is input, "P-Err" indicating an error is displayed.

In this case, press the keys [↑] or [↓] to return to "S-00."
Follow the procedures again from the step 4.



Display indicating a password error

7. Press the [SET] key.

- Again, "0" is displayed on the extreme right, and the underscore blinks on the extreme left.

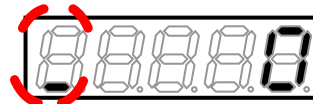

8. Press the [→] key to blink a required digit, and then press the keys [↑] or [↓] to change the number to "103."

- The display of the setting value automatically returns to that of the setting item in ten seconds. Unless a setting value is specified while it is displayed, it cannot be changed.



9. Press the [SET] key.

- The display of the setting value automatically returns to that of the setting item in ten seconds. Unless the [SET] key is pressed while a setting value is displayed, it is not confirmed.
- The change is confirmed, and "StoV2" and "SurE" blink alternately.

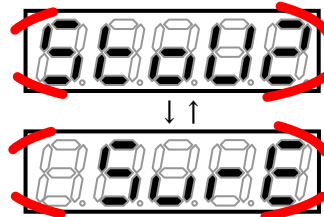

10. Press the [SET] key.

- The setting is confirmed, and "StoV2" is displayed.



Data is being transferred

- When the version of the converter main unit is different from the software version number of <SET66R-Z>, "VErr" blinks.
- Press the [STOP/RESET] key to interrupt copying data. Press the [SET] key to continue to copy data.



- Data is transferred from the converter main unit to <SET66R-Z>. When it has been completed successfully, "End" is displayed.
- When communication between the main unit and <SET66EX-Z> is disconnected during transfer, transfer is interrupted.



Data transfer has been completed

- (1) Interrupted with the setting block displayed
- (2) Interrupted ten seconds after blinking "rErr"

In either case, the setting block is displayed after interruption and then the monitor item display returns. Perform again the procedures from the first step.



Error indication

- Five seconds later, the converter series name is displayed, and then contents similar to what are displayed at power-on are displayed. Refer to {4.1.2. What Are Displayed at Power-on}.



■ Comparing data between the converter main unit and <SET66R-Z>

To compare setting data between the converter main unit and <SET66R-Z>, perform the following steps:

This function is useful when setting data of <SET66R-Z> shall be original data of multiple converters.

Use "104" of the Special mode selection <S-00>.

For details of the special mode selection: S-00, refer to {5. 3. 14. Area S}. For details of how to change parameter settings, refer to {4. 2. 3. Changing Parameter Settings}.

When the external console option is connected

- When <SET66R-Z> has been connected to the converter main unit, the console on the main unit cannot be used. Also, when the main unit cannot communicate with <SET66R-Z>, <SET66R-Z> does not react. Check connections between them and others.

1. Connect the console of the converter main unit to <SET66R-Z>.

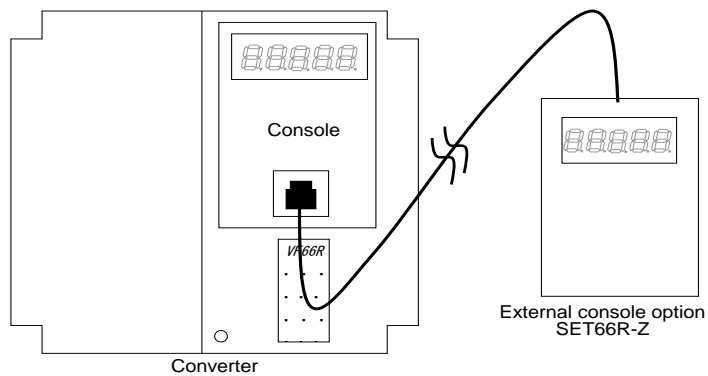

2. When the [FNC] LED on the console is off, press the [MONI/FNC] key.

- The [FNC] LED turns on, and a setting item appears in the seven-segment display. For example, immediately after the converter is turned on, the first item of the basic setting area is displayed.

3. Press the keys [↑] or [↓] to display "S-00."



4. Press the [SET] key.

- "0" is displayed on the extreme right, and the underscore blinks on the extreme left.

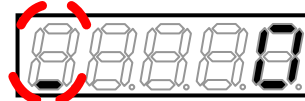

5. Press the [→] key to blink required digits, and then press the keys [↑] or [↓] to specify numbers to become "1040."



6. Press the [SET] key.

- The password input is confirmed, and the screen returns to "S-00" display.
- When a different number from "1040" is input, "P-Err" indicating an error is displayed. In this case, press the keys [↑] or [↓] to return to "S-00." Follow the procedures again from the step 4.



Display indicating a password error

7. Press the [SET] key.

- Again, "0" is displayed on the extreme right, and the underscore blinks on the extreme left.

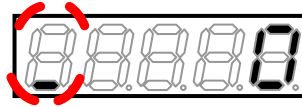

8. Press the [→] key to blink a required digit, and then press the keys [↑] or [↓] to change the number to "104."

- The display of the setting value automatically returns to that of the setting item in ten seconds. Unless a setting value is specified while it is displayed, it cannot be changed.



9. Press the [SET] key.

- The display of the setting value automatically returns to that of the setting item in ten seconds. Unless the [SET] key is pressed while a setting value is displayed, it is not confirmed.
- The change is confirmed, and "ConP" and "SurE" blink alternately.

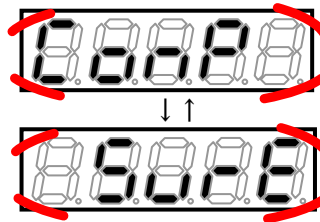

10. Press the [SET] key.

- The setting is confirmed, and "ConP" is displayed.



Data is being compared

- Compare data of the converter main unit with that of <SET66R-Z>. When they match, "End" is displayed.

- Setting data does not match:
Any of "CErr1," "CErr2" and "CErrA" blinks.

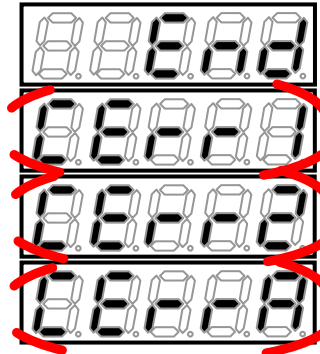

- When communication between the main unit and <SET66EX-Z> is disconnected during transfer, transfer is interrupted.

- (1) Interrupted with the setting block displayed
- (2) Interrupted ten seconds after blinking "rErr"

In either case, the setting block is displayed after interruption and then the monitor item display returns. Perform again the procedures from the first step.



Communication error indication

- In a few seconds, the setting block is displayed, and then a monitor item is displayed.



5. 4. 3. DC Voltage Detection Gain Adjustment

To change the Vdc detection gain <L-00> automatically, perform the following steps:

Use the Vdc adjustment <S-03>.

For details of the Vdc adjustment: <S-03>, refer to {5. 3. 14. Area S}. For details of how to change parameter settings, refer to {4. 2. 3. Changing Parameter Settings}.



Warning Safety notice

- High voltage is applied to a DC voltage meter or a tester. Experts should measure voltage.
- Close the front cover before turning on the power. Otherwise, it can result in a risk of electric shock.



Warning Safety notice

- To measure DC voltage, use a DC voltage meter or a tester which can measure 500 V or more for the 200 V class converter and 1000 V or more for the 400 V class.

Prepared items

- Phillips screwdriver (M3)
- Phillips screwdriver (M4)
- DC voltage meter or tester

1. Turn off the converter.

2. Open the front cover.

- For how to open the front cover, refer to {3. 2. How to Open and Close Front Cover}.
- Use the Phillips screwdriver (M4).

3. Install a DC voltage meter or tester between the DC terminals [+] and [-] on the main circuit terminal block of the converter.

- For the terminal block and the position of terminals, refer to {3. 3. 1. How to Connect Converter Terminals}.
- Use the Phillips screwdriver (M3).

4. Close the front cover and turn on the converter.

5. When the [FNC] LED on the console is off, press the [MONI/FNC] key.

- The [FNC] LED turns on, and a setting item appears in the seven-segment display. For example, immediately after the converter is turned on, the first item of the basic setting area is displayed.

6. Press the keys [↑] or [↓] to display "S-00."



7. Press the [→] key to blink numbers, and then press the keys [↑] or [↓] to change them to become "S-03."



8. Press the [SET] key.

· "0" is displayed on the extreme right, and the underscore blinks on the extreme left.

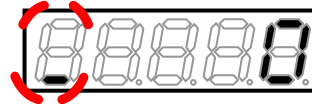

9. Press the [→] key to blink required digits, and then press the keys [↑] or [↓] to specify numbers to become "1040."



10. Press the [SET] key.

· The password input is confirmed, and the screen returns to "S-03" display.

· When a different number from "1040" is input, "P-Err" indicating an error is displayed. In this case, press the keys [↑] or [↓] to return to "S-03."

Follow the procedures again from the step 8.

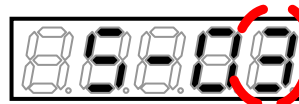

Display indicating a password error

11. Press the [SET] key.

· "0" is displayed on the extreme right, and the underscore blinks on the extreme left.

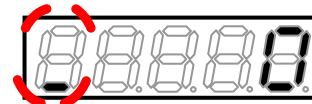

12. Press the [→] key to blink required digits, and then press the keys [↑] or [↓] to change numbers to a value measured by the voltage meter or the tester.

· The display of the setting value automatically returns to that of the setting item in ten seconds. Unless a setting value is specified while it is displayed, it cannot be changed.



Specify "339" if the measured value is 339.6V

13. Press the [SET] key.

· The display of the setting value automatically returns to that of the setting item in ten seconds. Unless the [SET] key is pressed while a setting value is displayed, it is not confirmed.

· The setting of the DC voltage detection gain: L-00 is automatically changed, and then "S-03" is displayed again.



14. Press the [MONI/FNC] key.

- The [FNC] LED turns off, after a monitor item is displayed for about one second, its data appears.



DC voltage: Vdc

15. Turn off the converter, and open the front cover.

16. Remove the installed DC voltage meter or tester.

17. Close the front cover.

5.4.4. Analog Input (2) and (3) Gain and Offset Adjustment

The sections {5.4.4.} and {5.4.5.} describe how to adjust analog input/output gain and offset automatically with area S parameters.

Analog input (2) and (3) adjustment

- Analog input (2) and (3) require an optional board such as <I066-Z>.
When these optional boards are not used, the settings and adjustment described below are not required.

This section describes the procedures for changing the gain and offset of analog input (2) and (3), with the following example of the analog input (2) gain and offset: L-09 and L-10 when <I066-Z> is used.

Use the analog input (2) characteristics selection: L-07 and the analog input (2) adjustment: S-05 parameters. For details of the analog input (2) characteristics selection: L-07, refer to {5.3.10. Area L}. For details of the analog input (2) adjustment: S-05, refer to {5.3.14. Area S}. For details of how to change parameter settings, refer to {4.2.3. Changing Parameter Settings}.

Analog Input (3) Gain and Offset Adjustment

- For analog input (3) gain and offset, refer to the area L.
- Specify setting items of the area L and area S to meet the analog input (3) gain and offset. Then, follow the procedures below.



Warning Short-circuit of terminals

- Be sure to turn off the converter before short-circuiting the terminals.
Otherwise, it can result in a risk of electric shock.



Caution Measuring voltage between terminals

- Great care must be taken not to touch electrical wires and terminals when measuring voltage between terminals.
Otherwise, it can result in a risk of electric shock.

Prepared items

- Phillips screwdriver (M3)
- Phillips screwdriver (M4)
- DC voltage generator
- DC voltage meter or tester

1. When the [FNC] LED on the console is off, press the [MONI/FNC] key.

- The [FNC] LED turns on, and a setting item appears in the seven-segment display. For example, immediately after the converter is turned on, the first item of the basic setting area is displayed.

2. Press the keys [↑] or [↓] to display "L-00."



3. Press the [→] key to blink numbers, and then press the keys [↑] or [↓] to change them to "L-07."

- For details of the analog input (2) characteristics selection: L-07, refer to {5.3.10. Area L}.



4. Press the [SET] key.

- The selection of "L-07" is confirmed, and the current setting value (Initialized data is "0") is displayed.
- The display of the setting value automatically returns to that of the setting item in ten seconds. Unless a setting value is specified while it is displayed, it cannot be changed.

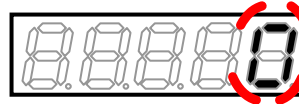

5. Press the keys [↑] or [↓] to change the number to "0" (0 to 10 V).



6. Press the [SET] key.

- The change is confirmed, and "L-07" is displayed again.
- The display of the setting value automatically returns to that of the setting item in ten seconds. Unless the [SET] key is pressed while a setting value is displayed, the change cannot be confirmed.



7. Turn off the converter.

8. Open the front cover.

- For how to open the front cover, refer to {3.2. How to Open and Close Front Cover}.
- Use the Phillips screwdriver (M4).

9. Short circuit the terminals [AIN2], [G], and [G-IN] on the terminal block of <I066-Z>.

- For the terminal block and the position of terminals, refer to {3.3.1. How to Connect Converter Terminals}.
- Use the Phillips screwdriver (M3).

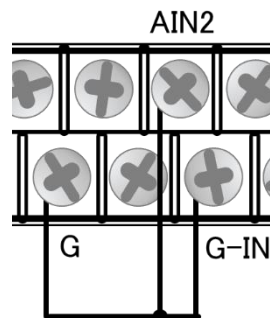

10. Close the front cover and turn on the converter.

11. Press the [MONI/FNC] key.

- The [FNC] LED turns on, and a setting item appears in the seven-segment display. For example, immediately after the converter is turned on, the first item of the basic setting area is displayed.

12. Press the keys [↑] or [↓] to display "S-00."



13. Press the [→] key to blink numbers, and then press the keys [↑] or [↓] to change them to "S-05."

- For details of the analog input (2) adjustment: S-05, refer to [5.3.14. Area S].



14. Press the [SET] key.

- "0" is displayed on the extreme right, and the underscore blinks on the extreme left.



15. Press the [→] key to blink required digits, and then press the keys [↑] or [↓] to specify "1040."



16. Press the [SET] key.

- The password input is confirmed, and the screen returns to "S-05" display.
- When a different number from "1040" is input, "P-Err" indicating an error is displayed. In this case, press the keys [↑] or [↓] to return to "S-05." Follow the procedures again from the step 14.

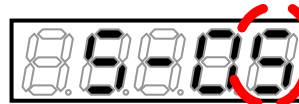

Display indicating a password error

17. Press the [SET] key.

- Again, "0" is displayed on the extreme right, and the underscore blinks on the extreme left.

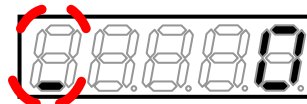

18. Press the [→] key to blink a required digit, and then press the keys [↑] or [↓] to change the number to "1."

- The display of the setting value automatically returns to that of the setting item in ten seconds. Unless a setting value is specified while it is displayed, it cannot be changed.

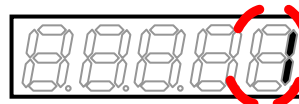

19. Press the [SET] key.

- The change is confirmed, and "S-05" is displayed again.
- The display of the setting value automatically returns to that of the setting item in ten seconds. Unless the [SET] key is pressed while a setting value is displayed, it is not confirmed.



20. Turn off the converter, and open the front cover.

21. Remove the short-circuit wire between the terminals [AIN2] and [G-IN] on <I066-Z>.

22. Connect a voltage generator to the terminals [AIN2] and [G-IN].

- Keep the terminals [G] and [G-IN] on <I066-Z> short-circuited.

23. Install a DC voltage meter or tester between the terminals [AIN2] and [GND].

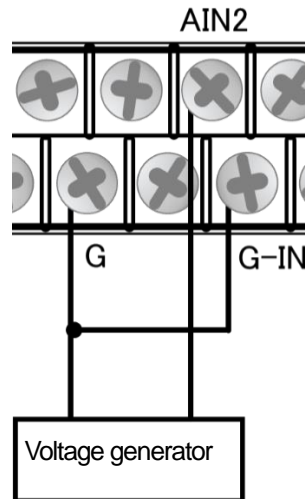

24. Close the front cover and turn on the converter.

25. Press the [MONI/FNC] key.

- The [FNC] LED turns on, and the first setting item of the basic setting area is displayed.

26. Press the keys [↑] or [↓] to display "S-00."



27. Press the [→] key to blink numbers, and then press the keys [↑] or [↓] to change them to "S-05."

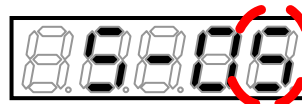

28. Press the [SET] key.

- "0" is displayed on the extreme right, and the underscore blinks on the extreme left.



29. Press the [→] key to blink required digits, and then press the keys [↑] or [↓] to specify "1040."



30. Press the [SET] key.

- The password input is confirmed, and the screen returns to "S-05" display.
 - When a different number from "1040" is input, "P-Err" indicating an error is displayed. In this case, press the keys [↑] or [↓] to return to "S-05."
- Follow the procedures again from the step 28.



Display indicating a password error

31. Press the [SET] key.

- "0" is displayed on the extreme right, and the underscore blinks on the extreme left.

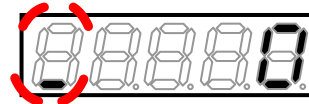

32. Apply 10 V with the voltage generator and press the [→] key to blink required digits, and then press the keys [↑] or [↓] to specify a value 1000 times a value measured by the voltage meter or the tester.

- Inputting a value 1000 times a voltage value of the analog input (2) enables gain adjustment of the analog input (2).



Specify "9983" if the measured value is 9.983V

33. Press the [SET] key.

- When "S-05" is displayed again, the settings of the analog input (2) gain: L-9 and analog input (2) offset: L-10 are automatically changed.

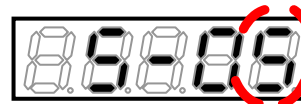

34. Press the [MONI/FNC] key.

- The [FNC] LED turns off, after a monitor item is displayed for about one second, its data appears.

35. Turn off the converter, and open the front cover.

36. Remove the wire attached to the terminals [AIN2], [G] and [G-IN] on <I066-Z>.

37. Remove the installed DC voltage meter or tester.

38. Close the front cover.

5.4.5. Analog Output (2) and (3) Gain and Offset Adjustment

The sections {5.4.4.} and {5.4.5.} describe how to adjust analog input/output gain and offset automatically with area S parameters.

Analog output (2) and (3) adjustment

- Analog output (2) and (3) require an optional board such as <I066-Z>. When these optional boards are not used, the settings and adjustment described below are not required.

This section describes the procedures for changing the gain and offset of analog output (2) and (3), with the following example of the analog output (2) gain and offset: L-03 and L-04 when <I066-Z> is used.

Be sure to do this after adjusting offset and gain of the analog input (2).

Use the analog output (2) characteristics selection: L-01 and the analog output (2) adjustment: S-06 parameters. For details of the analog input (2) characteristics selection and analog output (2) characteristics selection, refer to {5.3.10. Area L}. For details of the analog output (2) adjustment, refer to {5.3.14. Area S}. For details of how to change parameter settings, refer to {4.2.3. Changing Parameter Settings}.

Analog Output (3) Gain and Offset Adjustment

- For analog output (3) gain and offset, refer to the area L.
- Specify setting items of the area L and area S to meet the analog output (3) gain and offset. Then, follow the procedures below.

Warning Short-circuit of terminals

- Be sure to turn off the converter before short-circuiting the terminals. Otherwise, it can result in a risk of electric shock.

Prepared items

- Phillips screwdriver (M3)
- Phillips screwdriver (M4)

1. Turn off the converter, and open the front cover.

- For how to open the front cover, refer to {3.2. How to Open and Close Front Cover}.
- Use the Phillips screwdriver (M4).

2. Short circuit the terminals [AIN2] and [AIN2] on <I066-Z>.

- Use the Phillips screwdriver (M3).

3. Short circuit the terminals [G] and [G-OT] on <I066-Z>.

- Use the Phillips screwdriver (M3).

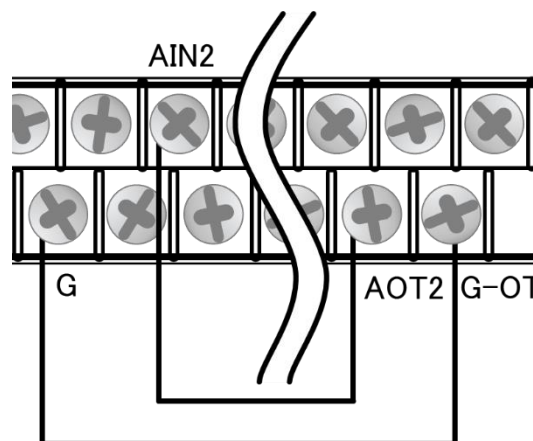

4. Close the front cover and turn on the converter.

5. Press the [MONI/FNC] key.

- The [FNC] LED turns on, and a setting item appears in the seven-segment display. For example, immediately after the converter is turned on, the first item of the basic setting area is displayed.

6. Press the keys [↑] or [↓] to display "L-00."

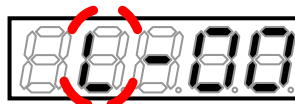

7. Press the [→] key to blink numbers, and then press the keys [↑] or [↓] to change them to "L-07."

- For details of the analog input (2) characteristics selection: L-07, refer to {5.3.10. Area L}.

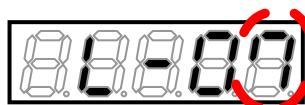

8. Press the [SET] key.

- The selection of "L-07" is confirmed, and the current setting value (Initialized data is "0") is displayed.
- The display of the setting value automatically returns to that of the setting item in ten seconds. Unless a setting value is specified while it is displayed, it cannot be changed.



9. Press the keys [↑] or [↓] to change the number to "0" (0 to 10 V).

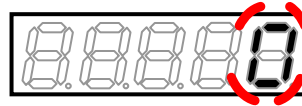

10. Press the [SET] key.

- The change is confirmed, and "L-07" is displayed again.
- The display of the setting value automatically returns to that of the setting item in ten seconds. Unless the [SET] key is pressed while a setting value is displayed, the change cannot be confirmed.

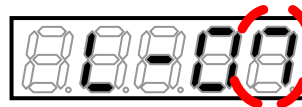

11. Press the [→], [↑] or [↓] keys to specify "L-01."

- For details of the analog output (2) characteristics selection: L-01, refer to {5.3.10. Area L}.

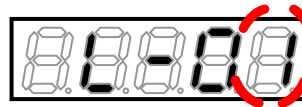

12. Press the [SET] key.

- The selection of "L-01" is confirmed, and the current setting value (Initialized data is "0") is displayed.

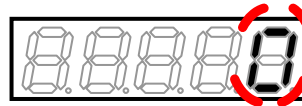

13. Press the keys [↑] or [↓] to change the number to "0" (AC voltage).

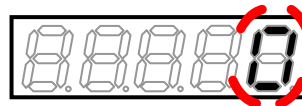

14. Press the [SET] key.

- The change is confirmed, and "L-01" is displayed again.

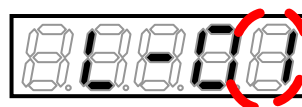

15. Press the [→], [↑] or [↓] keys to specify "S-06."

- For details of the analog output (2) adjustment: S-06, refer to {5.3.14. Area S}.

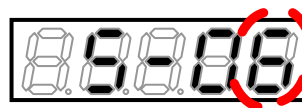

16. Press the [SET] key.

- "0" is displayed on the extreme right, and the underscore blinks on the extreme left.



17. Press the [→] key to blink required digits, and then press the keys [↑] or [↓] to specify numbers to become "1040."



18. Press the [SET] key.

- The password input is confirmed, and the screen returns to "S-06" display.
 - When a different number from "1040" is input, "P-Err" indicating an error is displayed. In this case, press the keys [↑] or [↓] to return to "S-06."
- Follow the procedures again from the step 16.



Display indicating a password error

19. Press the [SET] key.

- "0" is displayed on the extreme right, and the underscore blinks on the extreme left.



20. Press the [→] key to blink a required digit, and then press the keys [↑] or [↓] to change the number to "1" (Analog output (2) offset adjustment).

- The display of the setting value automatically returns to that of the setting item in ten seconds. Unless a setting value is specified while it is displayed, it cannot be changed.

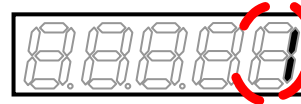

21. Press the [SET] key.

- The change is confirmed, and "S-06" is displayed again.
- The display of the setting value automatically returns to that of the setting item in ten seconds. Unless the [SET] key is pressed while a setting value is displayed, it is not confirmed.



22. Press the [→], [↑] or [↓] keys to specify "L-01."

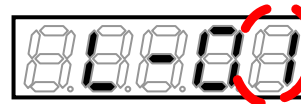

23. Press the [SET] key.

- The selection of "L-01" is confirmed, and the current setting value "0" (AC voltage) is displayed.



24. Press the keys [↑] or [↓] to change the number to "6" (Calibration).

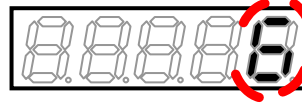

25. Press the [SET] key.

- The change is confirmed, and "L-01" is displayed again.



26. Press the [→], [↑] or [↓] keys to specify "S-06."



27. Press the [SET] key.

- "0" is displayed on the extreme right, and the underscore blinks on the extreme left.

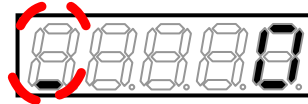

28. Press the [→] key to blink required digits, and then press the keys [↑] or [↓] to specify "1040."



29. Press the [SET] key.

- The password input is confirmed, and the screen returns to "S-06" display.
- When a different number from "1040" is input, "P-Err" indicating an error is displayed. In this case, press the keys [↑] or [↓] to return to "S-06."
Follow the procedures again from the step 27.



Display indicating a password error

30. Press the [SET] key.

- Again, "0" is displayed on the extreme right, and the underscore blinks on the extreme left.

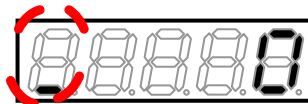

31. Press the [→] key to blink a required digit, and then press the keys [↑] or [↓] to change the number to "2" (Analog output (2) gain adjustment).

- The display of the setting value automatically returns to that of the setting item in ten seconds. Unless a setting value is specified while it is displayed, it cannot be changed.

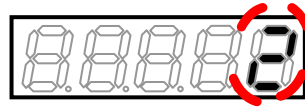

32. Press the [SET] key.

- The display of the setting value automatically returns to that of the setting item in ten seconds. Unless the [SET] key is pressed while a setting value is displayed, it is not confirmed.
- When "S-06" is displayed again, the settings of the analog output (2) gain: L-03 and analog output (2) offset: L-04 are automatically changed.



33. Press the [MONI/FNC] key.

- The [FNC] LED turns off, after a monitor item is displayed for about one second, its data appears.

34. Turn off the converter, and open the front cover.

35. Remove the short-circuit wire between the terminals [AOT2] and [AIN2] on <I066-Z>.

36. Remove the short-circuit wire between the terminals [G] and [G-OT] on <I066-Z>.

37. Close the front cover.

Chapter 6 Troubleshooting

6.1. Protection Messages and Actions

6.1.1. Displays and Behaviors in Protection Display Mode

When the converter starts a protection operation due to an abnormality while it operates, it stops operation, and the console enters the protection display mode to display the started protection.

For notification, the protection operation blinks in the seven-segment display.

For what are displayed, refer to {6.1.2. List of Protection Messages}.

Refer to this list and then take actions as described in {6.1.3. How to Handle Protection Messages}.

■ Displays in the protection display mode

When a single protection starts

The started protection operation blinks.

- The protection message is prepended with "1."



When multiple protections start

The protection operations are numbered in the order in which they are detected, and they will blink.

- They are displayed in turn every one second.

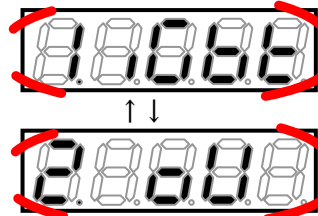

■ Behaviors of the converter in the protection display mode

- Stop operation (with some exceptions)
- Enable protection contact [86A] output (with some exceptions)















■ Operations in the protection display mode



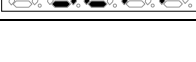



- (1) Even during a protection operation, you can press the [MONI/FNC] key to switch to the monitor (MONI) mode or the function setting (FNC) mode to operate the converter.
 - To handle a protection operation, you should sometimes change parameter settings.
- (2) Six types of protection operation data (such as AC current) can be displayed, and a state when an abnormality occurs can be checked.
 - Refer to {6.2.1. How to Display Protection Operation Data}.
- (3) Before performing reset, find a cause of a protection operation and take any measures.
 - For how to perform reset, refer to {6.3. How to Reset Protection Display Mode}.

6.1.2. List of Protection Messages

The table below lists what appear in the seven-segment display on the console when the converter starts a protection operation due to an abnormality while it operates.

■ Common to all models



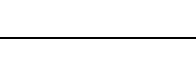

Display	Protection item	Description
	Overcurrent protection	An instantaneous value of AC current becomes more than or equal to 3.58 times of the rated converter current.
	IGBT protection	IGBT is protected from overcurrent or the gate power supply is decreased.
	Emergency stop A	The multifunction input specified for the emergency stop A (Normally open) has been ON.
	Emergency stop B	The multifunction input specified for the emergency stop B (Normally closed) has been OFF.
	Overvoltage protection of DC part	[200 V class] Voltage of the DC part exceeds 400 V. [400 V class] Voltage of the DC part exceeds 800 V.
	Overload protection	An effective value of AC current exceeds a 150 % of the rated current for 60 seconds.
	Current sensor failure	Current sensor fails.
	Startup stall	It starts when the converter cannot operate in ten seconds after an operation command is input.
	Low voltage (power failure)	[200 V class] DC voltage drop less than or equal to 180 V while the converter is running. [400 V class] DC voltage becomes less than or equal to 360 V while the converter is running. or AC power supply is in an abnormal state. [200 V class] AC voltage becomes less than or equal to 140 Vrms while the converter is running. [400 V class] AC voltage becomes less than or equal to 280 Vrms while the converter is running. or The current control error is 10 % and the operation command is ON. or It starts when the phase deviation is large (PWM sine wave mode: 18° or more, 120-degree conduction mode: 36° or more)
	Unit overheat protection	Temperature of IGBT becomes more than or equal to a specified value.
	Memory failure	Setting data stored in the built-in memory cannot be obtained correctly.
	Optional board error	A connected optional board malfunctions while the use of optional board: J-00 is enabled.
	Communication timeout error	A communication error (timeout) occurs between the optional board and the communication master while the network communication option is used.
	FCL operation	The high-speed current limit protection (FCL) lasts for ten seconds.
	Setting error	The operation is started while an error occurs in the setting such







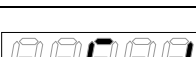
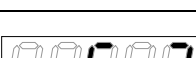
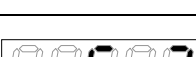



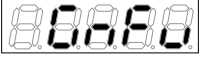

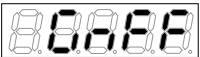
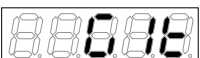

Display	Protection item	Description
		as AC reactor constant. (“—” in the last two digits shows a number to specify the location of setting error (in decimal notation).)
	CPU abnormality handling	CPU has an abnormal operation due to instantaneous reduction of control power supply 5 V or other reasons. (“—” in the last digit shows a number to distinguish errors.)
	Fan failure	The cooling fan fails. The operation is not stopped for protection.
	External failure 1	The multifunction input external failure 1 has been input.
	External failure 2	The multifunction input external failure 2 has been input.
	External failure 3	The multifunction input external failure 3 has been input.
	External failure 4	The multifunction input external failure 4 has been input.
	Blown AC fuse	The fuse of the AC part is blown.
	Mode error	There is no input to the MI3 terminal block of <VFC66R-Z> in the PWM sine wave mode, or when there is input to the MI3 terminal block of <VFC66R-Z> in the 120-degree conduction mode.

















For models 7522, 7544 and higher, and parallel models 15022, 18022, 40044 through 100044, the protection items listed below are displayed in addition to the above list.







For models 7522 through 9022, and 7544 through 31544 consisting of a single unit, the protection items (related to master units) listed in the next table are displayed.

Models 7522, 7544 and higher, and parallel models

Display	Protection item	Description
	Gate board abnormality	Protection related to the following gate board starts and the protection operation relay is activated.
	Gate board communication abnormality (master unit)	An abnormality in a communication with the gate board <GAC66> in the master unit.
	Gate power supply abnormality (master unit)	Power supply of the gate in the master unit has an abnormality.
	IGBT (L1/R phase) protection operation (master unit)	Overcurrent is applied to the L1/R phase IGBT in the master unit.
	IGBT (L2/S phase) protection operation (master unit)	Overcurrent is applied to the L2/S phase IGBT in the master unit.
	IGBT (L3/T phase) protection operation (master unit)	Overcurrent is applied to the L3/T phase IGBT in the master unit.
	Unit overheat (L1/R phase) (master unit)	Heat sink temperature of the L1/R phase IGBT in the master unit becomes more than or equal to a specified value.
	Unit overheat (L2/S phase) (master unit)	Heat sink temperature of the L2/S phase IGBT in the master unit becomes more than or equal to a specified value.

Display	Protection item	Description
	Unit overheat (L3/T phase) (master unit)	Heat sink temperature of the L3/T phase IGBT in the master unit becomes more than or equal to a specified value.
	Blown fuse (master unit)	For models over 75 kW and parallel models, Fuse of the main circuit DC part in the master unit is blown. or Magnetic contactor (MC) in the master unit does not turn on.
	FCL operation	Current over 290 % of the rated converter current is applied for ten or more seconds in all units.
	Power supply abnormality	For parallel models, Power supply of the parallel control board <PRIM66-Z> or <PRIS66-Z> has an abnormality.
	Failed fan (master unit)	For models over 75 kW and parallel models, Cooling fan in the master unit fails. However, the operation is not stopped for protection.
	Gate board communication abnormality (slave unit 1)	Abnormality occurs in a communication with the gate board <GAC66> in the slave unit 1.
	Gate power supply abnormality (slave unit 1)	Gate power supply in the slave unit 1 has an abnormality.
	IGBT (L1/R phase) protection operation (slave unit 1)	Overcurrent is applied to the L1/R phase IGBT in the slave unit 1.
	IGBT (L2/S phase) protection operation (slave unit 1)	Overcurrent is applied to the L2/S phase IGBT in the slave unit 1.
	IGBT (L3/T phase) protection operation (slave unit 1)	Overcurrent is applied to the L3/T phase IGBT in the slave unit 1.
	DC part overvoltage (slave unit 1)	DC part is protected from overvoltage in the slave unit 1. [200 V class] Voltage of the DC part exceeds 400 V. [400 V class] Voltage of the DC part exceeds 800 V.
	Unit overheat (L1/R phase) (slave unit 1)	Heat sink temperature of the L1/R phase IGBT in the slave unit 1 becomes more than or equal to a specified value.
	Unit overheat (L2/S phase) (slave unit 1)	Heat sink temperature of the L2/S phase IGBT in the slave unit 1 becomes more than or equal to a specified value.
	Unit overheat (L3/T phase) (slave unit 1)	Heat sink temperature of the L3/T phase IGBT in the slave unit 1 becomes more than or equal to a specified value.
	Blown fuse (slave unit 1)	Fuse of the main circuit DC part in the slave unit 1 is blown. or Magnetic contactor (MC) in the slave unit 1 does not turn on.
	Failed fan (slave unit 1)	Cooling fan in the slave unit 1 fails. However, the operation is not stopped for protection.
	Control power supply abnormality (slave unit 1)	Voltage of the control power supply in the slave unit 1 has an abnormality.
	Gate board communication	Abnormality occurs in a communication with the gate board <GAC66> in the slave unit 2.

Display	Protection item	Description
	abnormality (slave unit 2)	
	Gate power supply abnormality (slave unit 2)	Power supply of the gate in the slave unit 2 has an abnormality.
	IGBT (L1/R phase) protection operation (slave unit 2)	Overcurrent is applied to the L1/R phase IGBT in the slave unit 2.
	IGBT (L2/S phase) protection operation (slave unit 2)	Overcurrent is applied to the L2/S phase IGBT in the slave unit 2.
	IGBT (L3/T phase) protection operation (slave unit 2)	Overcurrent is applied to the L3/T phase IGBT in the slave unit 2.
	DC part overvoltage (slave unit 2)	DC part is protected from overvoltage in the slave unit 2. [200 V class] Voltage of the DC part exceeds 400 V. [400 V class] Voltage of the DC part exceeds 800 V.
	Unit overheat (L1/R phase) (slave unit 2)	Heat sink temperature of the L1/R phase IGBT in the slave unit 2 becomes more than or equal to a specified value.
	Unit overheat (L2/S phase) (slave unit 2)	Heat sink temperature of the L2/S phase IGBT in the slave unit 2 becomes more than or equal to a specified value.
	Unit overheat (L3/T phase) (slave unit 2)	Heat sink temperature of the L3/T phase IGBT in the slave unit 2 becomes more than or equal to a specified value.
	Blown fuse (slave unit 2)	Fuse of the main circuit DC part in the slave unit 2 is blown. or Magnetic contactor (MC) in the slave unit 2 does not turn on.
	Failed fan (slave unit 2)	Cooling fan in the slave unit 2 fails. However, the operation is not stopped for protection.
	Control power supply abnormality (slave unit 2)	Voltage of the control power supply in the slave unit 2 has an abnormality.
	Gate board communication abnormality (slave unit 3)	Abnormality occurs in a communication with the gate board <GAC66> in the slave unit 3.
	Gate power supply abnormality (slave unit 3)	Power supply of the gate in the slave unit 3 has an abnormality.
	IGBT (L1/R phase) protection operation (slave unit 3)	Overcurrent is applied to the L1/R phase IGBT in the slave unit 3.
	IGBT (L2/S phase) protection operation (slave unit 3)	Overcurrent is applied to the L2/S phase IGBT in the slave unit 3.
	IGBT (L3/T phase) protection operation (slave unit 3)	Overcurrent is applied to the L3/T phase IGBT in the slave unit 3.

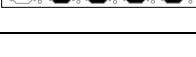
Display	Protection item	Description
	DC part overvoltage (slave unit 3)	DC part is protected from overvoltage in the slave unit 3. [200 V class] Voltage of the DC part exceeds 400 V. [400 V class] Voltage of the DC part exceeds 800 V.
	Unit overheat (L1/R phase) (slave unit 3)	Heat sink temperature of the L1/R phase IGBT in the slave unit 3 becomes more than or equal to a specified value.
	Unit overheat (L2/S phase) (slave unit 3)	Heat sink temperature of the L2/S phase IGBT in the slave unit 3 becomes more than or equal to a specified value.
	Unit overheat (L3/T phase) (slave unit 3)	Heat sink temperature of the L3/T phase IGBT in the slave unit 3 becomes more than or equal to a specified value.
	Blown fuse (slave unit 3)	Fuse of the main circuit DC part in the slave unit 3 is blown. or Magnetic contactor (MC) in the slave unit 3 does not turn on.
	Failed fan (slave unit 3)	Cooling fan in the slave unit 3 fails. However, the operation is not stopped for protection.
	Control power supply abnormality (slave unit 3)	Voltage of the control power supply in the slave unit 3 has an abnormality.

Console error displays

Display	Protection item	Description
	Communication timeout error	Communication timeout between the control board <VFC66R-Z> and the console board <SET66-Z>.

6.1.3. How to Handle Protection Messages

When the converter starts a protection operation due to an abnormality while it operates, you should follow instructions in the seven-segment display to take actions listed below.

■ Common to all models

Display	Cause	Where to check and how to take actions	Reference
	The output electrical wire was grounded or short circuited.	Check the wiring of the output electrical wire.	3.3 How to Connect Converter
	Load capacity is abnormally large.	<ul style="list-style-type: none"> Reduce load. Check and review the converter model. 	
	Operation level setting is inappropriate.	Review the operation level setting value.	
	Combination between the converter and inverter on the motor control side is inappropriate.	Use a correct combination between the converter and inverter on the motor control side.	

Display	Cause	Where to check and how to take actions	Reference
	Ambient temperature becomes high.	<ul style="list-style-type: none"> Check the installation environment. Check whether temperature inside the control panel rises or not. 	3.1.2 How to Install Converter
	Cooling space of the converter is not enough.	Keep enough cooling space.	3.1.2 How to Install Converter
	The installation direction of the converter is not correct.	Install it in the correct direction.	3.1.2 How to Install Converter
	The output electrical wire was grounded or short circuited.	Check the wiring of the output electrical wire.	3.3 How to Connect Converter
	IGBT is damaged.	Check whether IGBT works properly or not (continuity check).	
	The cooling fan fails.	Replace the cooling fan.	7.3 How to Replace Cooling Fan
	The wind of the cooling fan blows in the reverse direction.	Install it so that the wind blows in the correct direction.	7.3 How to Replace Cooling Fan
	The gate board <GAC66> malfunctions.	Replace the gate board <GAC66>.	

Display	Cause	Where to check and how to take actions	Reference
	(This is not a display for protection.)	The multifunction terminal specified for the emergency stop (normally open) has been turned ON.	
	(This is not a display for protection.)	The multifunction terminal specified for the emergency stop (Normally closed) has been turned OFF.	

Display	Cause	Where to check and how to take actions	Reference
	The output electrical wire was grounded or short circuited.	Check the wiring of the output electrical wire.	3.3 How to Connect Converter
	AC power supply voltage abnormally rises.	Check the AC power supply voltage.	
	Control gain setting is inappropriate.	Review the control gain.	
	Constant setting of the inverter on the motor control side is inappropriate.	Review the setting of the inverter on the motor control side.	

Display	Cause	Where to check and how to take actions	Reference
	Rated converter current is too small.	<ul style="list-style-type: none"> Reduce load. Check and review the converter model. 	
	A value of the overload protection setting for overload protection is not correct.	Check and review a setting value of the overload protection setting: F-00.	5.3.7 Area F
	Load capacity is abnormally large.	Use the overload pre-alarm function: c-11.	5.3.4 Area c

Display	Cause	Where to check and how to take actions	Reference
	Current sensor failure	Replace the current sensor.	
	Input current flow when the converter stops	Check the input current.	
		Make sure that inverter operation enable (TB1 4I) is required to start an inverter	

Display	Cause	Where to check and how to take actions	Reference
	Insufficient DC voltage ($\sqrt{2}$ times the AC power supply voltage or lower)	Check the DC voltage.	
	Main circuit wiring is incorrect.	Check the wiring.	
	AC power failure occurs.	Check the AC power supply voltage.	

Display	Cause	Where to check and how to take actions	Reference
	Input power fails (instantaneous power failure) during operation.	Check the input power supply.	
	Open phase occurred in the input power supply.	Check the input power supply.	

Display	Cause	Where to check and how to take actions	Reference
	The cooling fan of the converter fails or malfunctions.	Replace the cooling fan of the converter.	
	Ambient temperature is high, or cooling space of the converter is not enough.	Check the installation environment, and check that cooling space is enough.	3.1.2 How to Install Converter
	The installation direction of the converter is not correct.	Install it in the correct direction.	3.1.2 How to Install Converter

Display	Cause	Where to check and how to take actions	Reference
	Data was written incorrectly to the EEPROM (built-in memory) due to too much noise.	Take measures against noise for a wiring from the control board <VFC66R-Z>.	3.5.1 Notes for Wiring
	The uninitialized control board <VFC66R-Z> was implemented.	Initialize the control board <VFC66R-Z>.	8.3 How to Initialize Converter Main Unit
	Faulty EEPROM (built-in memory) parts.	Replace the control board <VFC66R-Z>.	8.2 How to Replace Control Board

Display	Cause	Where to check and how to take actions	Reference
	The option usage selection: J-00 is set to "ON" without the option connected.	Set the option usage selection: J-00 to "OFF."	5.3.9 Area J
	An option malfunctions.	Replace the option.	Optional Operating Instructions
	An option is not connected properly.	Check the connection with the option and the connector insertion status.	Optional Operating Instructions





Display	Cause	Where to check and how to take actions	Reference
	Communication setting error	Check the communication settings of the master and converter.	
	The communication master malfunctions.	Check behaviors of the communication master.	
	The cable between the optional printed board and communication master is disconnected, or the connector is not inserted properly.	Check the connector insertion status or replace the connection cable.	

Display	Cause	Where to check and how to take actions	Reference
	The output electrical wire was grounded or short circuited.	Check the wiring of the output electrical wire.	3.3 How to Connect Converter
	Load capacity is abnormally large.	<ul style="list-style-type: none"> · Reduce load. · Check and review the converter model. 	
	Operation level setting is inappropriate.	Review the operation level setting value.	

Display	Cause	Where to check and how to take actions	Reference
	It starts when a setting value is incorrect.	Check the setting parameter.	

Display	Cause	Where to check and how to take actions	Reference
	It starts due to instantaneous reduction of control power supply 5 V, etc.	Check the connection of [CN1] on the control board <VFC66R-Z>.	8.2 How to Replace Control Board (Note) When this problem is not solved even after both actions are taken, you should contact us.
	The control board <VFC66R-Z> or gate board <GAC66> malfunctions.	Replace the board.	

Display	Cause	Where to check and how to take actions	Reference
	The cooling fan of the converter fails.	Check the cooling fan of the converter.	

Display	Cause	Where to check and how to take actions	Reference
	The external failure signal was input.	Check conditions where it is input.	
  	Multifunction input settings are not correct.	Check multifunction input settings of c-01 through c-06.	5.3.4 Area c

Display	Cause	Where to check and how to take actions	Reference
	Excessive current flows to the converter output.	Check the wiring of the input/output electrical wire. Replace the damaged parts and fuse.	
	IGBT is damaged.	Check whether IGBT works properly or not (continuity check). Replace the damaged parts, fuse and unit.	
	The output electrical wire was grounded or short circuited.	Check the wiring of the output electrical wire. Replace the damaged parts and fuse.	
	FUSE (+) and FUSE (-) on TB1 of <VFC66R-Z> are open.	Check if FUSE (+) and FUSE (-) on TB1 of <VFC66R-Z> are open.	

Display	Cause	Where to check and how to take actions	Reference
	There is no input to the MI3 terminal block of <VFC66R-Z> while the PWM sine wave mode is selected.	Enable input to the MI3 terminal block of <VFC66R-Z> while the PWM sine wave mode is selected.	4.1.1 About the Control Mode
	There is input to the MI3 terminal block of <VFC66R-Z> while the 120-degree conduction mode is selected.	Disable input to the MI3 terminal block of <VFC66R-Z> while the 120-degree conduction mode is selected.	

■ Models 7522, 7544 and higher, and parallel models

For models 7522 through 9022, and 7544 through 31544 consisting of a single unit, the items (related to master units) listed below are displayed.

Parallel models are 15022, 18022, and 40044 through 100044.

Display	Cause	Where to check and how to take actions	Reference
	The protection related to <GAC66> starts.	Clear the protection operation related to <GAC66> that is displayed at the same time.	6.1.2 List of Protection Messages

Display	Cause	Where to check and how to take actions	Reference
	The gate board <GAC66> malfunctions.	Replace the gate board <GAC66>.	
	The cable between the master unit gate board <GAC66> and slave unit gate board <GAC66>, or the cable between slave unit gate boards <GAC66> is disconnected, or the connector is not inserted properly.	<ul style="list-style-type: none"> Check that the connector is inserted correctly. Replace the connection cable. 	

* A character in the second digit from the right distinguishes a master unit (n) from slave units (1, 2, and 3).

Display	Cause	Where to check and how to take actions	Reference
	The gate power supply of the gate board <GAC66> was decreased.	Replace the gate board <GAC66> of the displayed converter.	

* A character in the second digit from the right distinguishes a master unit (n) from slave units (1, 2, and 3).

Display	Cause	Where to check and how to take actions	Reference
	The output electrical wire was short circuited or grounded.	Check the wiring of the output electrical wire.	3.3 How to Connect Converter
	IGBT may be damaged.	Check whether IGBT of the converter works properly or not (continuity check).	
	DC voltage command is too high or too low.	Review the DC voltage command.	
	Load capacity is abnormally large.	<ul style="list-style-type: none"> · Reduce load. · Check and review the converter model. 	
	The gate board <GAC66> malfunctions.	Replace the gate board <GAC66> of the converter.	

* A character in the second digit from the right distinguishes a master unit (n) from slave units (1, 2, and 3).

* A number in the rightmost digit shows the L1/R phase (1), L2/S phase (2), and L3/T phase (3).



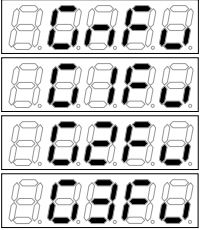

Display	Cause	Where to check and how to take actions	Reference
	The cooling fan of the converter stops or its air volume is decreased due to failure or malfunction.	Replace the cooling fan.	7.3 How to Replace Cooling Fan
	The wind of the cooling fan of the converter blows in the reverse direction.	Install it so that the wind blows in the correct direction.	7.3 How to Replace Cooling Fan
	Ambient temperature is high.	Check temperature in the installation environment (such as temperature inside the control panel) for ventilation.	3.1.2 How to Install Converter
	Cooling space of the converter is not enough.	Keep enough cooling space around the converter.	3.1.2 How to Install Converter
	The installation direction of the converter is not correct.	Install it in the correct direction.	3.1.2 How to Install Converter
	The heat sink temperature sensor malfunctions.	Measure resistance of the heat sink temperature sensor.	

Display	Cause	Where to check and how to take actions	Reference
	IGBT may be damaged.	Check whether IGBT works properly or not (continuity check), and then replace the fuse of the main circuit DC part.	
	The output electrical wire was grounded or short circuited.	Check input and output wires. After correcting them, replace the damaged parts and the fuse of the main circuit DC part.	
	The magnetic contactor (MC) does not turn ON.	<ul style="list-style-type: none"> · The connector between the gate board <GAC66> and the power supply board <PSFM66> is not connected properly. Check the connection status of the connector. · Check the connection between the terminal block MI4 input, magnetic contactor auxiliary contact and fuse indicator. · The power supply board <PSFM66> malfunctions. Replace it. · Replace the magnetic contactor (MC). 	



* A character in the third digit from the right distinguishes a master unit (n) from slave units (1, 2, and 3).

Display	Cause	Where to check and how to take actions	Reference
	The output electrical wire was grounded or short circuited.	Check the wiring of the output electrical wire.	3.3 How to Connect Converter
	Load capacity is abnormally large.	<ul style="list-style-type: none"> · Reduce load. · Check and review the converter model. 	
	Operation level setting is inappropriate.	Review the operation level setting value.	



Display	Cause	Where to check and how to take actions	Reference
	The power supply of the parallel control board <PRIM66-Z> in the master unit or the parallel control board <PRIS66-Z> in the slave unit failed.	Replace the parallel control board <PRIM66-Z> or <PRIS66-Z>.	
	<GAC66>-CNPS24V and <PRIM66-Z>-CN9 of the master unit or <GAC66>-CNPS24V and <PRIS66-Z>-CN-PS of the slave unit are not wired.	Wire them correctly.	

Display	Cause	Where to check and how to take actions	Reference
	The cooling fan fails.	Check and replace the cooling fan.	
	The power supply for the cooling fan is decreased.	Replace the power supply board <PSFM66>.	
  	The wire between the gate board <GAC66> and the power supply board <PSFM66> is disconnected or incorrect.	Correct it.	
	The relay for turning on/off the cooling fan is not enabled.	Replace the power supply board <PSFM66>.	

* A character in the third digit from the right distinguishes a master unit (n) from slave units (1, 2, and 3).

Display	Cause	Where to check and how to take actions	Reference
  	The gate board <GAC66> malfunctions.	Replace the gate board <GAC66> of the displayed slave unit.	

* A character in the third digit from the right distinguishes a master unit (n) from slave units (1, 2, and 3).

Display	Cause	Where to check and how to take actions	Reference
	Input power supply voltage abnormally rises.	Check input power supply voltage.	
 	The output electrical wire was grounded or short circuited.	Check the wiring of the output electrical wire.	

* A character in the third digit from the right distinguishes a master unit (n) from slave units (1, 2, and 3).

■ Console error displays

Display	Cause	Where to check and how to take actions	Reference
	Insertion of the connectors of the console	Check the insertion status of defective connector.	
	The control board <VFC66R-Z> is in the program rewrite mode.	After rewriting of the program is completed, it is automatically restored.	
	The control board <VFC66R-Z> malfunctions.	Replace the control board <VFC66R-Z>.	8.2. How to Replace Control Board

6.2. How to Check Data in Protection Display Mode

6.2.1. How to Display Protection Operation Data

While a protection operation blinks, six types of data (such as DC voltage command) of the protection operation can be read out. This is called "one-point traceback data."

For details of displayed data, refer to {6.2.2. List of Data of Protection Operation and Protection History Display}.

1. The started protection operation blinks.

- When multiple protection operations started, they are numbered and displayed in turn every one second.

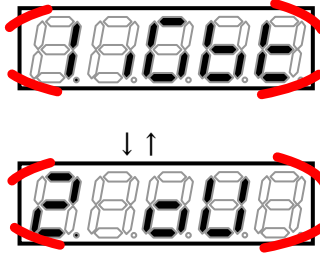

2. While the desired protection operation blinks, press the [SET] key.

- Data of the protection operation (one-point traceback) is displayed.
- Six items and their data are repeatedly displayed in turn every one second.

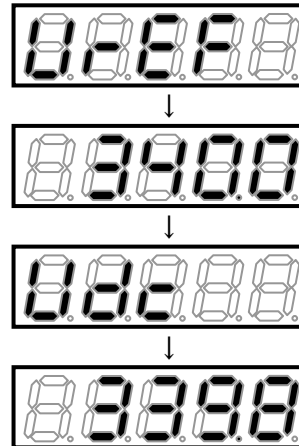







3. Press the [SET] key.

- The protection operation blinks again.
- For how to reset a protection operation, refer to {6.3. How to Reset Protection Display Mode}.

6.2.2. List of Data of Protection Operation and Protection History Display

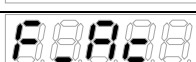
The tables below list data which can be checked as one-point traceback and protection history display during protection operation.

Data item	Display	Unit	Description	Remarks
DC voltage command		V	DC voltage command.	
DC voltage		V	The DC voltage.	
AC current		A	The maximum value of absolute three-phase AC current instantaneous values.	It is different from the display of the monitor item.
AC voltage		V	An effective value of AC line voltage.	
AC frequency		Hz	An AC frequency.	
AC power		kW	An AC active power.	Positive power is defined as flowing into power system.

In the tables, AC current shows a current value immediately before a protection operation occurs, out of sampled values every operation period. Therefore, when current changes at fast rise (such as output short-circuit), it may not show a correct current value when the protection occurs.

6.3. How to Reset Protection Display Mode

This section describes how to reset a protection operation and to return from the protection display mode. Before performing reset, find a cause of a protection operation and take any measures.

Behaviors after reset are as follows:

- One-point traceback data described in {6. 2. 1 How to Display Protection Operation Data} can be no longer checked.
- Protection contact [86A] output is disabled again.

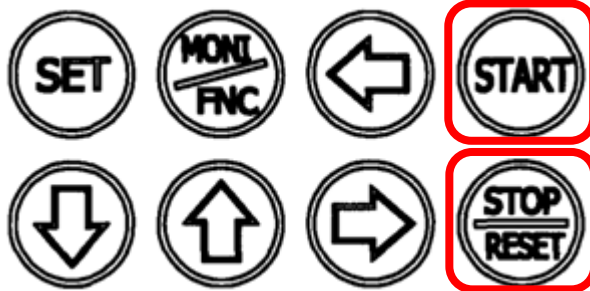

1. While the protection operation blinks, press the [STOP/RESET] key.

- The protection operation is reset.
- The mode returns to the monitor (MONI) mode immediately before the protection operation starts.



When the monitor item "Vdc" (DC voltage) is displayed again

Even after it is reset, it may occur again.

- When a cause of the protection operation has not been solved
- When multiple protections occurred and some of them have not been solved

Check the contents of the protection message again and take any measures.

6.4. How to Check Protection History

When the converter stops due to a protection operation, it stores data such as AC current and AC voltage of the protection.

You can always see and check data of the last six protection histories by selecting the monitor item "trbLE." For details of displayed items, refer to {6.2.2. List of Data of Protection Operation and Protection History Display}.

1. When the [FNC] LED on the console is on, press the [MONI/FNC] key.

- The [FNC] LED turns off, and the console enters the monitor (MONI) mode.
- The current monitor item is displayed for about one second, and then its data is automatically displayed.
- For details of the monitor (MONI) mode, refer to {4.2.4. Checking Operating State}. For details of monitor items, refer to {4.2.5. List of Monitor Items}.

2. Press either of the [SET] key, [↑] key, or [↓] key to return to the display of the monitor item.

3. Press either of the [SET] key, [↑] key, or [↓] key to display "trbLE" (display protection history).



- Unless you press any key within one second while the monitor item is displayed, you cannot change it.
- About one second later, up to last six protection operations are displayed in turn every one second.
- The protection history starting with the number "1." is the oldest.

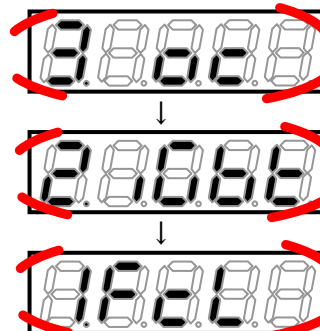

- When there is no protection history, "—" is displayed. Press the [SET] key to return to the display of the monitor item "trbLE."
- Press the [SET] key while the protection history is displayed to return to the display of the monitor item "trbLE."

4. While the protection history to check data is displayed, press the [SET] key for over three seconds.

- A data item of that protection operation is displayed.
- Six items and their data are displayed in turn every one second.

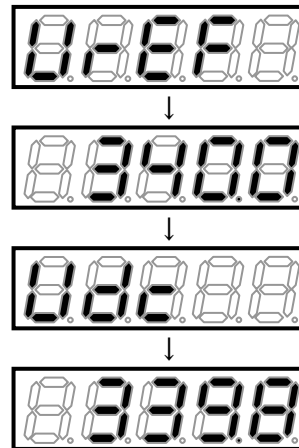

5. Press the [SET] key.

- The protection history is displayed again.

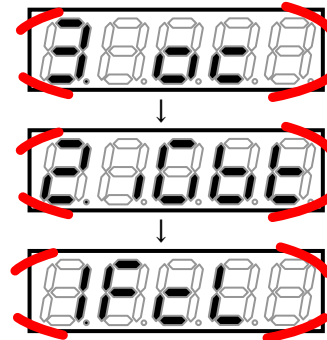

6. Press the [SET] key.

- The monitor item is displayed again.

Clearing protection history

- You can clear the stored protection history with S-00. For details, refer to {5.3.14. Area S}.

Chapter 7 Maintenance and Inspection

7.1. Periodic Inspection

To always keep the best condition of devices and to maximize their best performance, conduct a periodic inspection at least once every six months to check issues which cannot be found in a normal monitoring.

Persons with safety knowledge of electricity should conduct maintenance and inspection.

For how to open the front cover, refer to {3.2. How to Open and Close Front Cover}.



Warning Tasks of inspection

- Never open the front cover with the input power supply turned on. Otherwise, it can result in a risk of electric shock.
- Turn off the converter, open the front cover, and then check that the LED for checking "CHG" on the gate board <GAC66> turns off. After that, conduct an inspection. Otherwise, electric shock or injury may occur.



Caution Tasks of inspection

- Note that temperature of the heat sink may be high depending on operating conditions. Otherwise, you may get burned.



Warning Maintenance and inspection

- Before conducting an inspection, turn off the input power supply and wait for ten or more minutes. Also, check voltage between the DC terminals [+] and [-] on the main circuit terminal block to see if it is below 30 V. Otherwise, it can result in a risk of electric shock.
- Only certified persons should conduct maintenance and inspection. Take off metals (such as a watch and bracelet) before maintenance and inspection. Use a tool for insulation. Otherwise, electric shock or injury may occur.

■ Items and contents of periodic inspection

Inspection item and target	Inspection detail
Appearance of the converter	Check that the vent hole or the heat sink does not get blocked with dust, and clean them.
Cooling fan	When dust is attached to the cooling fan, you should clean it. Replace the cooling fan, considering a service life time of about 40,000 hours as a guide.
Inside the converter	Inspect and check that dust is not attached to each board and electronic parts.
Terminal block and terminal screw	Inspect the terminal block and mounting screws for looseness, and retighten them.
Connector	Check connectors and terminals on the control board <VFC66R-Z> for looseness.
Wiring	Check the insulating coating of the wiring for abnormalities such as cracks and deformation.
Main circuit capacitor	If it has any abnormalities such as electrolyte leakage or change of color, it should be replaced. For details, refer to {7.4. Inspecting and Replacing Main Circuit Capacitor}.

7.2. Main Circuit Capacitor/Cooling Fan Replacement Timing

■ When to replace the main circuit capacitor and cooling fan

The converter counts cumulative operation time in one hour.

You can check cumulative operation time by using the monitor item: tin0. At the same time, the remaining life of the main circuit capacitor and that of the cooling fan are displayed in the monitor items (timer remaining time 1: tin1 and timer remaining time 2: tin2) as a guide.

For details of monitor items, refer to {4.2.4. Checking Operating State} and {4.2.5. List of Monitor Items}.

When a value of the timer remaining time 1: tin1 becomes less than or equal to "0," this indicates that it is time to replace the main circuit capacitor and that replacement of the capacitor is recommended.



When a value of the timer remaining time 2: tin2 becomes less than or equal to "0," this indicates that it is time to replace the cooling fan and that replacement of the fan is recommended.

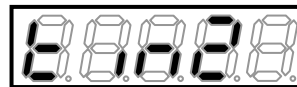

For replacing the main circuit capacitor, refer to {7.4. Inspecting and Replacing Main Circuit Capacitor}. For replacing the cooling fan, refer to {7.3. How to Replace Cooling Fan}.

■ Default setting of the cumulative operation timer

You can change a setting of cumulative operation time with the cumulative operation timer (1): F-02 and the cumulative operation timer (2): F-03. In the initial state, they are set as follows:

- Cumulative operation timer (1): F-02: Guide of remaining life of the main circuit capacitor
- Cumulative operation timer (2): F-03: Guide of remaining life of the cooling fan

Each amount of time indicates a guide of remaining life, and it does not assure their behaviors.

For details of F-02 and F-03, refer to {5.3.7. Area F}.

Initialized data of Cumulative_operation_timer(1) and Cumulative_operation_timer(2)

Cumulative operation timer (1): F-02	Cumulative operation timer (2): F-03
43800Hr	21900Hr

7.3. How to Replace Cooling Fan

This section describes how to replace the cooling fan.

The cooling fan is a component specific to each model of the converter. For replacement, use a cooling fan the same as the one installed on the converter.

For replaced parts of the cooling fan, contact us.



Warning Replaced parts

● Before conducting an inspection, turn off the input power supply and wait for ten or more minutes. Also, check voltage between the DC terminals [+] and [-] on the main circuit terminal block to see if it is below 30 V.

Otherwise, it can result in a risk of electric shock.

● Only certified persons should conduct maintenance and inspection. Take off metals (such as a watch and bracelet) before maintenance and inspection. Use a tool for insulation.

Otherwise, electric shock or injury may occur.



Caution Precautions concerning handling

● Handle parts with care not to make a powerful impact.

Deformation will cause a failure of the converter.

7.3.1. How to Remove Cooling Fan

This section describes how to typically remove the cooling fan.

For the cooling fan, its shape, number of pieces, the presence or absence of screws, and its position depend on your converter model.

For details of how to remove the cooling fan, contact us.



Caution Removing the cooling fan

● When removing the cooling fan, be careful not to put a strain on the electrical wire.

1. Use the Phillips screwdriver to loosen screws of the mounting plate of the cooling fan.
2. Slide the mounting plate of the cooling fan to the front side.

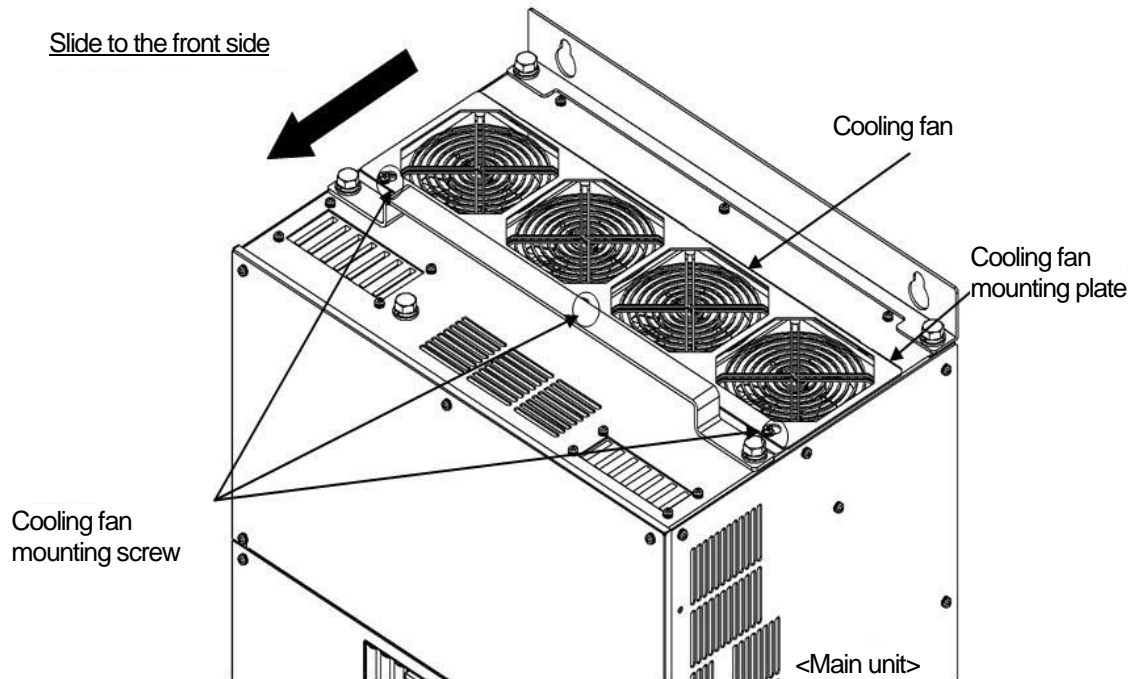

3. Incline and lift the plate.

- For some models, the plate is only to be unlocked (with no screw).

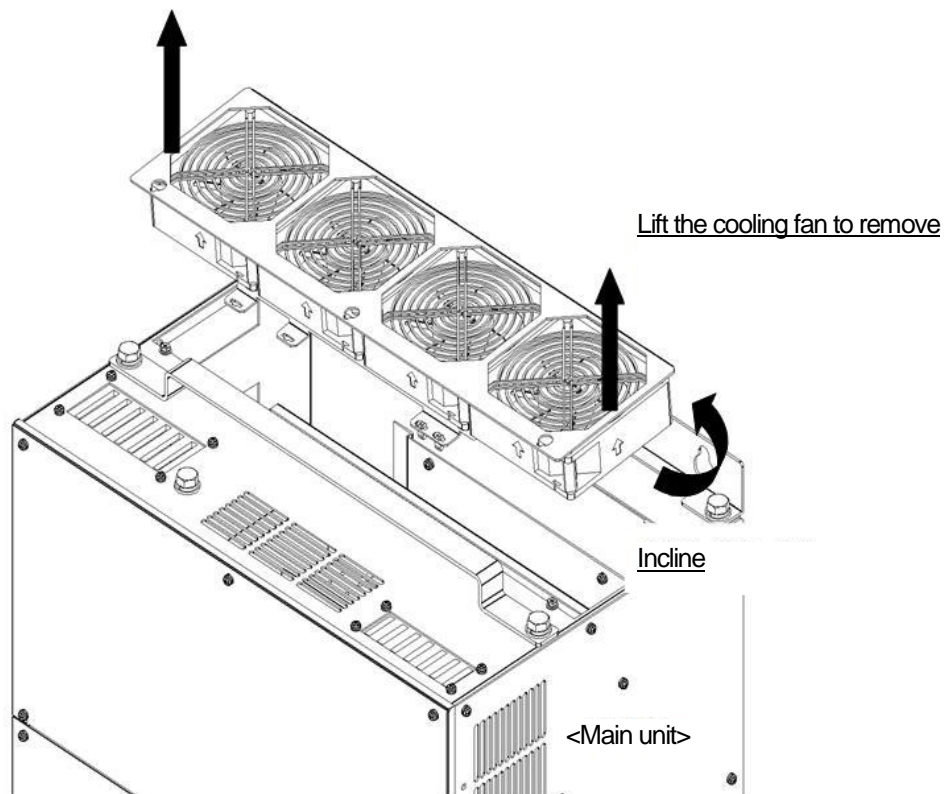

4. Pull out the connector of the electrical wire connected to the converter main unit.
5. Remove the connector of the cooling fan from the connector mounting plate of the cooling fan.

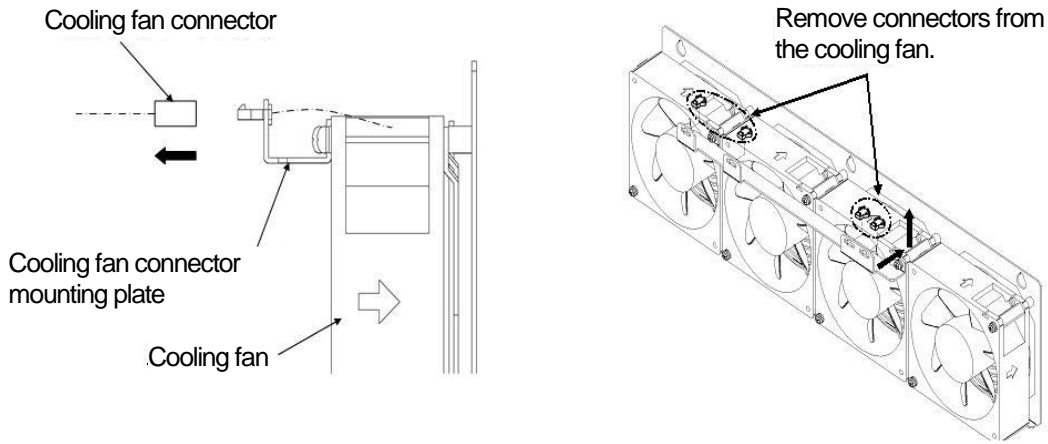

6. Use the Phillips screwdriver to remove screws, and remove the cooling fan from the plate.

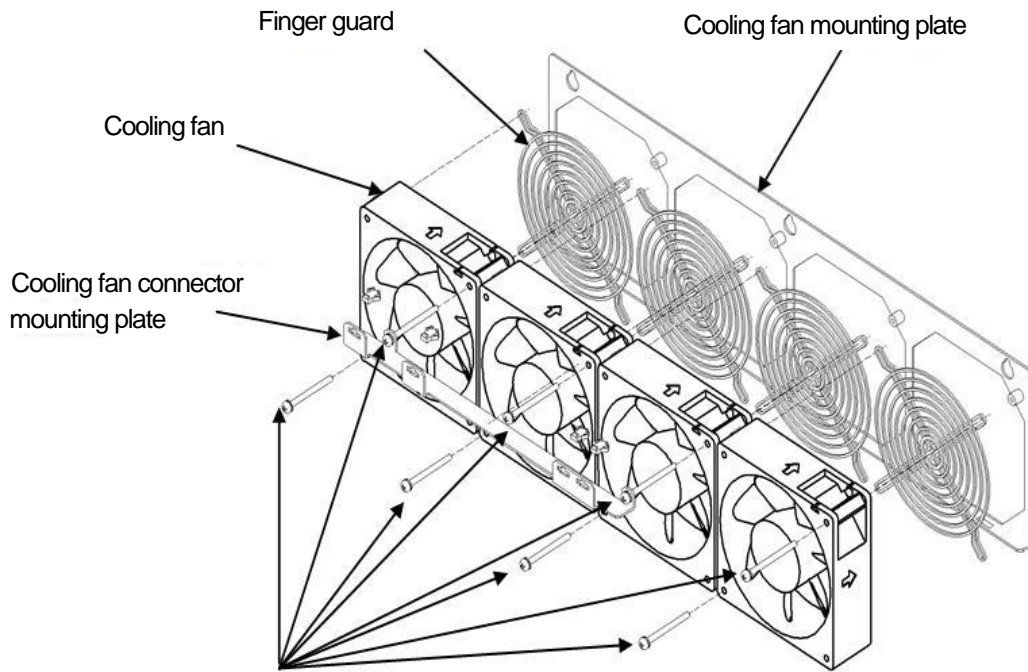

Remove screws using a Phillips screwdriver and remove the cooling fan.

7.3.2. How to Install Cooling Fan

This section describes how to typically install the cooling fan.

For the cooling fan, its shape, number of pieces, the presence or absence of screws, and its position depend on your converter model.

For details of how to install the cooling fan, contact us.

Caution Installation of the cooling fan

- Care should be taken that the lead wire does not get struck between the cooling fan and the main unit.
- Do not bend the lead wire tightly. Push it softly.
- Incorrect directions of the wind and the wiring slot of the cooling fan will cause a failure. Check them carefully and then install it.

1. Follow the procedures described in {7.3.1. How to Remove Cooling Fan} in the reverse order to install each part.
2. Connect the connector of the cooling fan to the connector of the electrical wire on the main unit.
 - For the pathway of the electrical wire of the cooling fan, put it in the state before the fan is removed.
3. Insert the mounting plate of the cooling fan so that the hole on the plate fits the claw on the chassis.
4. Use the Phillips screwdriver to tighten the screws of the mounting plate of the cooling fan.
 - For some model, the plate is only locked with no screw.

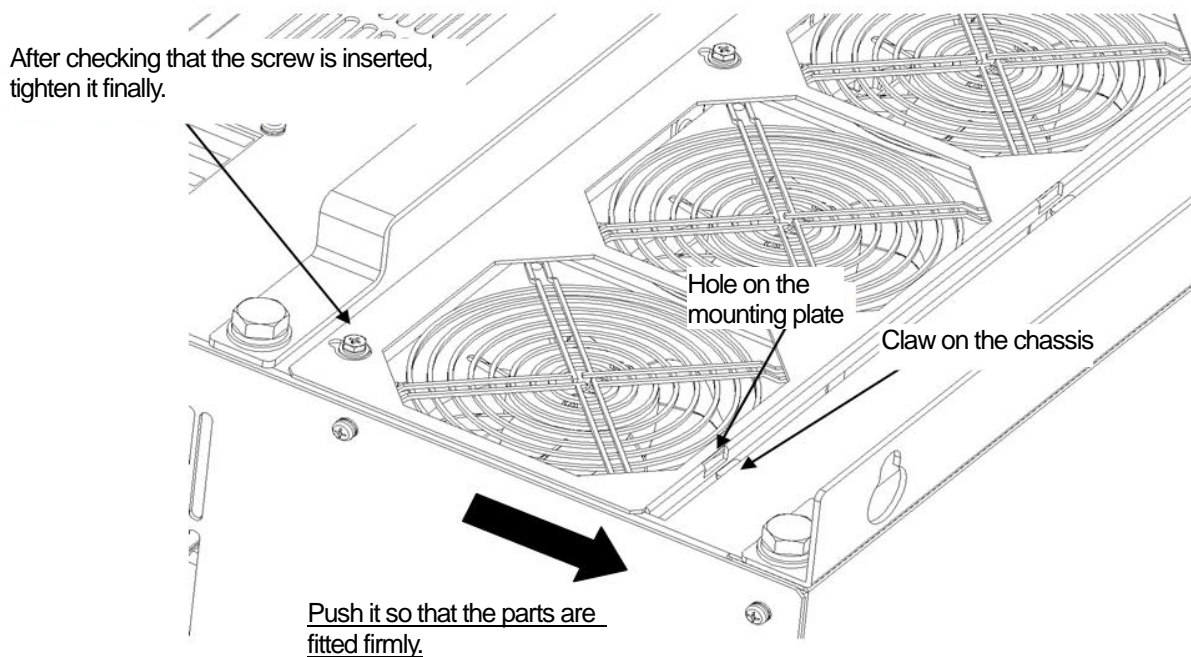

7.4. Inspecting and Replacing Main Circuit Capacitor

If any abnormalities of the main circuit capacitor (such as electrolyte leakage or change of color) are found in a periodic inspection, etc., you should contact us.

The converter indicates an expected life of the main circuit capacitor with the timer remaining time 1: tin1 of the monitor item.

When a value of the timer remaining time 1: tin1 becomes less than or equal to "0," replacement of the main circuit capacitor is recommended.

When the main circuit capacitor operates for 12 hours per day at the average ambient temperature of below 35 °C, it should be replaced in ten years as a guide.

Caution Main circuit capacitor

● Before using the converter which has been stored for three or more years as a spare, conduct aging of the main circuit capacitor. For aging, apply the rated input voltage to the converter for about eight hours with its output electrical wire removed.

If the capacitor is used without aging, it may be damaged, resulting in a dangerous situation.

7.5. How to Perform Insulation Resistance Test

When the board and the terminal block have been cleaned in a periodic inspection, etc., before operating the converter, you should perform the insulation resistance test of the main circuit and check it for short-circuit.

Use a megger with 500 VDC to perform the insulation resistance test.

Do not perform the insulation resistance test of the control circuit.

Prepared items

- Phillips screwdriver (M3)
- Phillips screwdriver (M4)
- Megger with 500 VDC

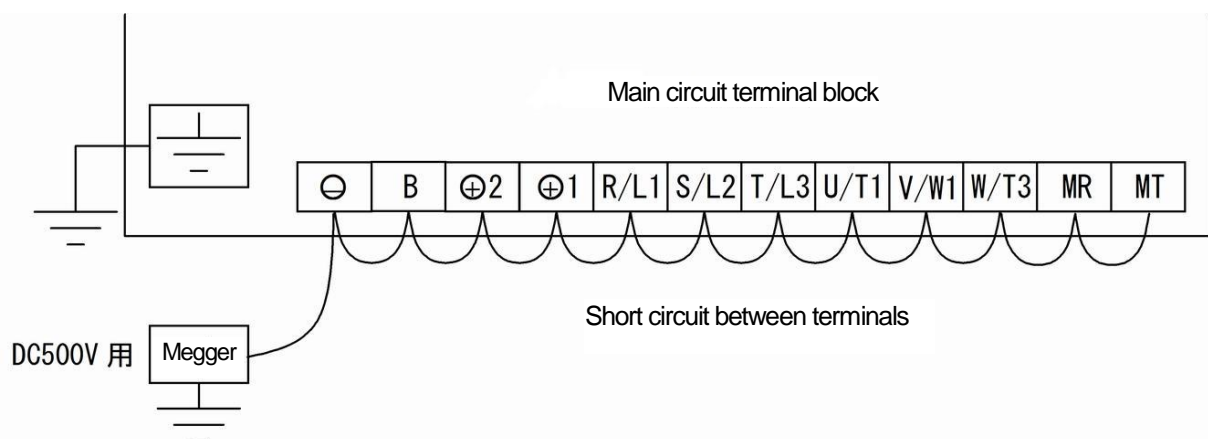

1. Turn off the converter, and open the front cover.

- For how to open the front cover, refer to {3.2. How to Open and Close Front Cover}.
- Use the Phillips screwdriver (M4).

2. Remove all wires.

- Use the Phillips screwdriver (M3).

3. Short circuit all terminals on the main circuit terminal block.

- For the terminal block and the position of terminals, refer to {3. 3. 1. How to Connect Converter Terminals}.

4. Measure insulation resistance between the terminals on the main circuit terminal block and the protective earth terminal.

- Check that insulation resistance is more than or equal to 10 M Ω .
- If it is less than 10 M Ω , contact us.

5. Remove all short-circuit wires.

6. Return the wires to the original state.

7. Close the front cover.

7.6. How to Discard Parts

To discard replaced parts or service parts, follow the instructions of each administrative agency.

Chapter 8 Replacing Control Board

8.1. Tasks Required for Replacing Control Board

After replacing the control board <VFC66R-Z> with a spare, the internal control parameters are factory-set initial values. Therefore, you need to reset them according to the currently used converter parameters.

About the control board <VFC66R-Z>

- The software dedicated for the converter is written to the control board <VFC66R-Z> incorporated in the converter.
- Be sure to replace the control board with the control board <VFC66R-Z> in which the software dedicated for the converter is written.

8.2. How to Replace Control Board (For VFC66R-Z-P1)

This section describes how to install the control board <VFC66R-Z> when the model is "VFC66R-Z-P1". Check that "VFC66R-Z-P1" is printed on the control board <VFC66R-Z>.

Warning

- Before replacing the control board <VFC66R-Z>, turn off the converter input power and wait at least 10 minutes. In addition, check the voltage between the DC terminals [+2] to [-] on the main circuit terminal block and confirm that it is 24V or less. Otherwise, it can result in a risk of electric shock.
- When connecting the control board <VFC66R-Z> and the connector of the option board, make sure the pins are not misaligned. Otherwise, electric shock, injury, failure or malfunction may occur.

Caution

- Do not connect and disconnect the connector too many times. Also, do not apply excessive force when attaching or detaching. It may cause damage to the connector or poor connection.
- Do not insert anything other than the matching connector. Doing so may deform the connector and cause poor connection.

Prepared items

- Spare of the control board <VFC66R-Z>
- Phillips screwdriver (M3)
- Phillips screwdriver (M4)
- Needle-nose plier

Open the front cover. The optional board is located in the front side, and the console board <SET66-Z> is located above the control board <VFC66R-Z> in the back.

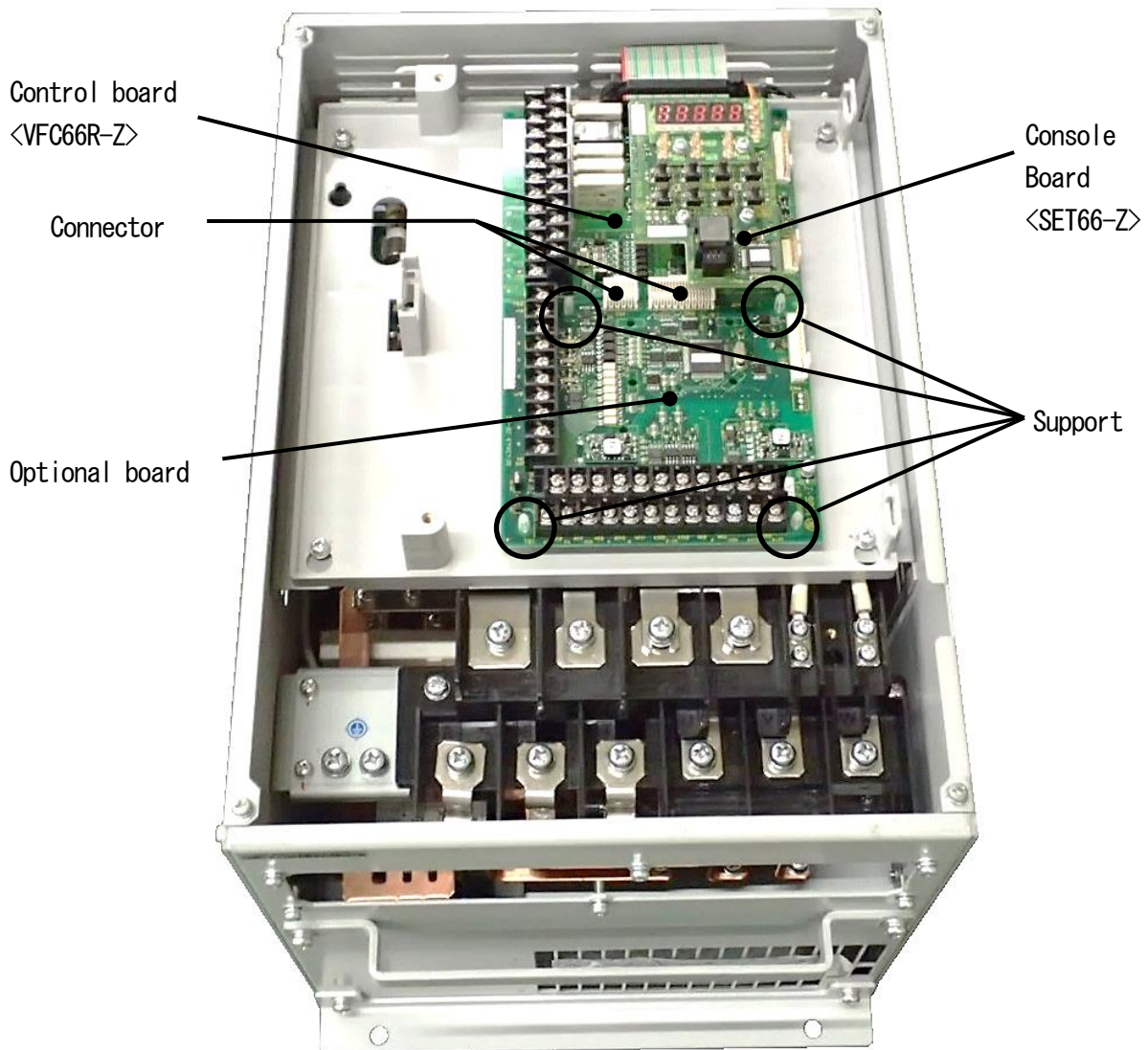

1. Turn off the converter.

2. Open the front cover.

- For how to open the front cover, refer to [3. 2. How to Open and Close Front Cover].
- Use the Phillips screwdriver (M4).

3. Remove four screws on the console board <SET66-Z>.

- Use the Phillips screwdriver (M3).

4. Remove the console board <SET66-Z>.

- Pull out the console board from the control board <VFC66R-Z> to remove it.

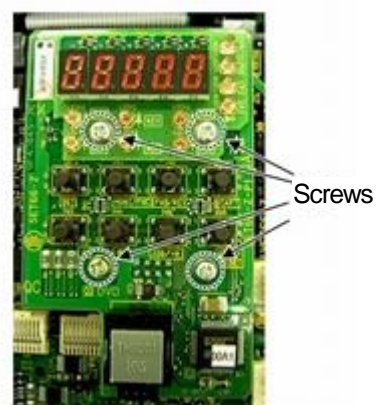

5. Remove the joint of two connectors between the control board <VFC66R-Z> and the optional board.

- Push up the knob to remove the joint of the connectors.

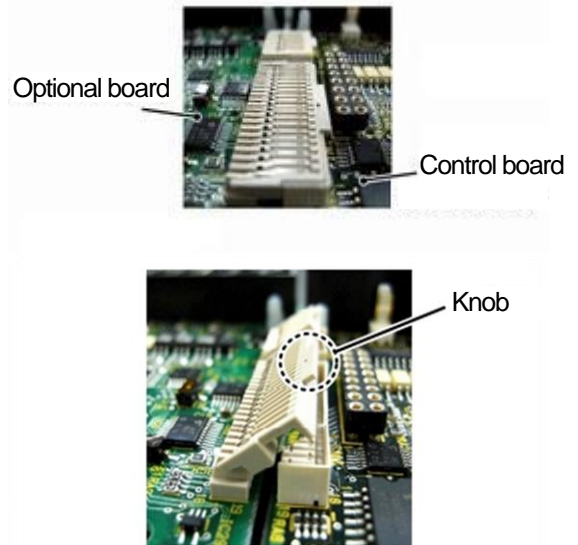

6. Push four claws of the support holding the optional board into the support.

- The support fixes the optional board to the chassis of the converter.
- When having a difficulty in pushing the claws, use a needle-nose plier.

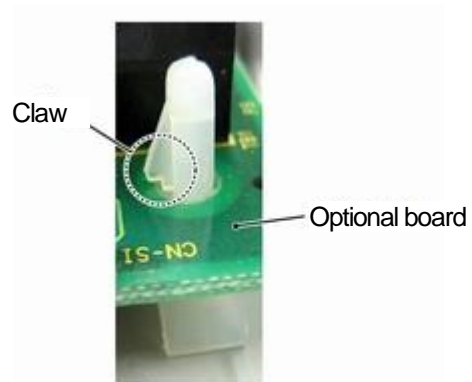

7. Remove the optional board.

8. Remove the flat cable of the control board <VFC66R-Z>.

9. Push four claws of the support holding the control board <VFC66R-Z> into the support.

- The control board <VFC66R-Z> is also fixed to the chassis of the converter with the support.
- When having a difficulty in pushing the claws, use a needle-nose plier.

10. Remove the control board <VFC66R-Z>.

11. Align four holes on a new control board <VFC66R-Z> to the support.

12. Push the control board <VFC66R-Z> until the claws of the support hang on the upper portion of the board.

13. Align the four holes on the removed optional board to the support.

14. Push the optional board until the claws of the support hang on the upper portion of the board.

15. Connect the flat cable of the control board <VFC66R-Z>.

16. Push up the knobs of the connectors [CN1] and [CN2] on the optional board.
17. Fix the connectors [CN1] and [CN2] into the connectors [CN7] and [CN4] on the control board <VFC66R-Z>.

- The moving part of the connector is elastic. If it is not installed tightly, it may be removed. Fix it tightly.

18. Install the console board <SET66-Z> and then tighten four screws.

- Use the Phillips screwdriver (M3).

19. Close the front cover of the converter.

- Use the Phillips screwdriver (M4).

8.3. How to Replace Control Board (For VFC66R-Z-P2)

This section describes how to install the control board <VFC66R-Z> when the model is "VFC66R-Z-P2". Check that "VFC66R-Z-P2" is printed on the control board <VFC66R-Z>.

Warning

- Before replacing the control board <VFC66R-Z>, turn off the converter input power and wait at least 10 minutes. In addition, check the voltage between the DC terminals [+2] to [-] on the main circuit terminal block and confirm that it is 24V or less. Otherwise, it can result in a risk of electric shock.
- When connecting the control board <VFC66R-Z> and the connector of the option board, make sure the pins are not misaligned. Otherwise, electric shock, injury, failure or malfunction may occur.

Caution

- Do not connect and disconnect the connector too many times. Also, do not apply excessive force when attaching or detaching. It may cause damage to the connector or poor connection.
- Do not insert anything other than the matching connector. Doing so may deform the connector and cause poor connection.

Prepared items

- Spare of the control board <VFC66R-Z>
- Phillips screwdriver (M3)
- Phillips screwdriver (M4)
- Needle-nose plier

Open the front cover. The optional board is located in the front side, and the console board <SET66-Z> is located above the control board <VFC66R-Z> in the back.

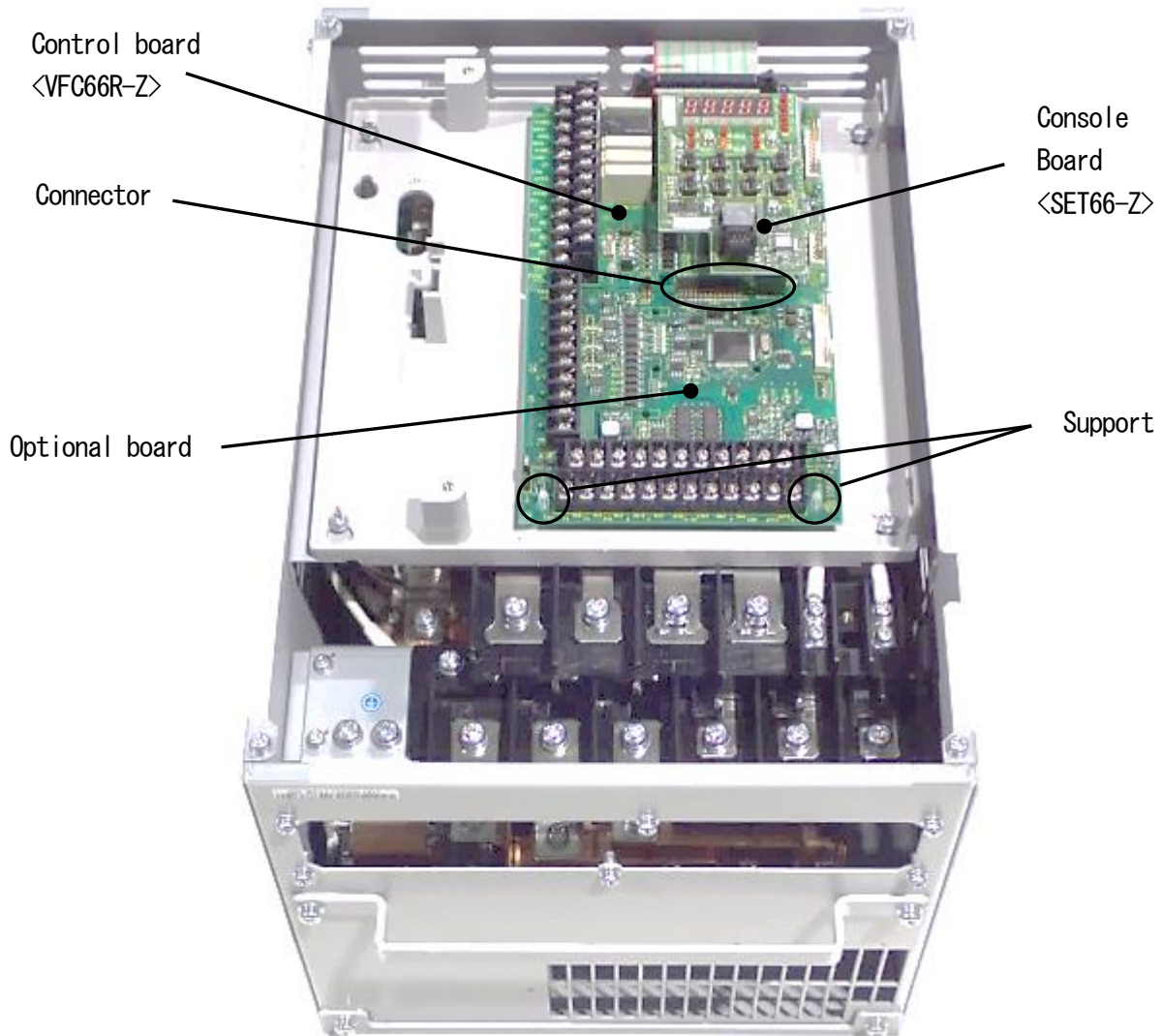

1. Turn off the converter.

2. Open the front cover.

- For how to open the front cover, refer to [3. 2. How to Open and Close Front Cover].
- Use the Phillips screwdriver (M4).

3. Remove four screws on the console board <SET66-Z>.

- Use the Phillips screwdriver (M3).

4. Remove the console board <SET66-Z>.

- Pull out the console board from the control board <VFC66R-Z> to remove it.

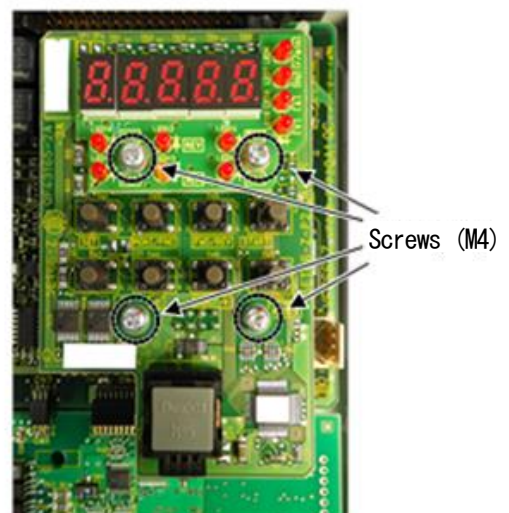

5. Push two claws of the support holding the optional board into the support.

- The support fixes the optional board to the chassis of the converter.
- When having a difficulty in pushing the claws, use a needle-nose plier.

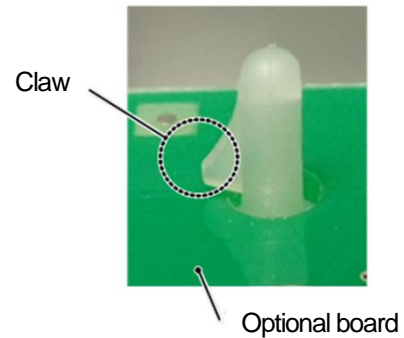

6. Remove the optional board.

- While lifting the bottom edge of the optional board in the direction of ①, pull it straight out in the direction of ②.
- Lift the option board up to the height of the support and do not apply excessive force to the connector.

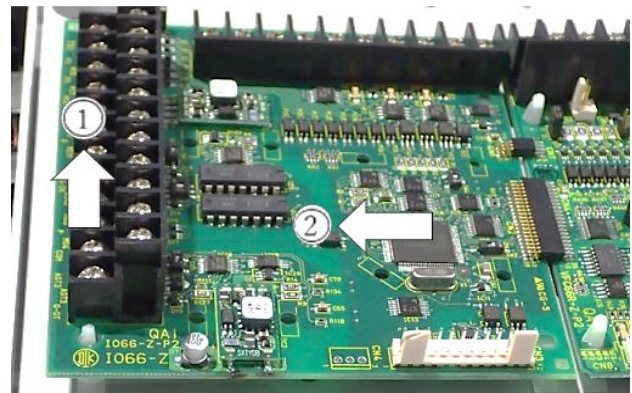

7. Remove the flat cable of the control board <VFC66R-Z>.

8. Push four claws of the support holding the control board <VFC66R-Z> into the support.

- The control board <VFC66R-Z> is also fixed to the chassis of the converter with the support.
- When having a difficulty in pushing the claws, use a needle-nose plier.

9. Remove the control board <VFC66R-Z>.

10. Align four holes on a new control board <VFC66R-Z> to the support.

11. Push the control board <VFC66R-Z> until the claws of the support hang on the upper portion of the board.

12. Connect the connectors [CN1] and [CN2] of the option board to the connectors [CN7] and [CN4] of the control board <VFC66R-Z> respectively.

- Make sure the pins of the connector are connected without misalignment.
- If the connection between the connectors is insufficient, gaps will occur between the connectors.



13. Align the two mounting holes on the option board with the support, and push it in until the claws of the support catch the option board.

14. Connect the flat cable of the control board <VFC66R-Z>.

15. Install the console board <SET66-Z> and then tighten four screws.

- Use the Phillips screwdriver (M3).

16. Close the front cover of the converter.

- Use the Phillips screwdriver (M4).

8.4. How to Initialize Converter Main Unit

You can set the converter model by initializing the converter.

Use the special mode selection: S-00.

For details of how to change parameter settings, refer to {4.2.3. Changing Parameter Settings}.

Initialization of the converter main unit

- Be sure to initialize the converter main unit after replacing the control board <VFC66R-Z>.



Warning Safety notice

- High voltage is applied to a DC voltage meter or a tester. Experts should measure voltage.
 - Close the front cover before turning on the power.
- Otherwise, it can result in a risk of electric shock.



Caution Safety notice

- To measure DC voltage, use a DC voltage meter or a tester which can measure 500 V or more for the 200 V class converter and 1000 V or more for the 400 V class.

Prepared items

- Phillips screwdriver (M3)
- Phillips screwdriver (M4)
- DC voltage meter or tester

1. Turn off the converter.

2. Open the front cover.

- For how to open the front cover, refer to {3.2. How to Open and Close Front Cover}.
- Use the Phillips screwdriver (M4).

3. Install a DC voltage meter or a tester between the DC terminals [+] and [-] on the main circuit terminal block of the converter.

- For the terminal block and the position of terminals, refer to {3.3.1. How to Connect Converter Terminals}.

4. Close the front cover and turn on the converter.

5. When the [FNC] LED on the console is off, press the [MONI/FNC] key.

- The [FNC] LED turns on, and a setting item appears in the seven-segment display. For example, immediately after the converter is turned on, the first item of the basic setting area is displayed.

6. Press the keys [↑] or [↓] to display "S-00."

- When the first item of the basic setting area is displayed, press the [↓] key once to display "S-00."
- For details of the special mode selection: S-00, refer to {5.3.14. Area S}.



7. Press the [SET] key.

- On the extreme right, "0" is displayed.
- The underscore blinks on the extreme left, which indicates that this becomes the operating digit.

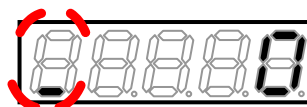

8. Press the [→] key to blink required digits, and then press the keys [↑] or [↓] to specify "1040."

- "1040" is a password. It is required to use the Special_mode_selection "S-00".



9. Press the [SET] key.

- The password input is confirmed, and the screen returns to "S-00" display.
- When a different number from "1040" is input, "P-Err" indicating an error is displayed. In this case, press the keys [↑] or [↓] to return to "S-00." Follow the procedures again from the step 7.
- Here, you can stop the initialization by pressing the [STOP/RESET] key.



Display indicating a password error

10. Press the [SET] key.

- Again, "0" is displayed on the extreme right, and the underscore blinks on the extreme left.

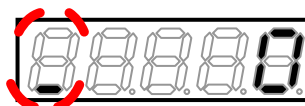

11. Press the [→] key to blink a required digit, and then press the keys [↑] or [↓] to change the number to "1" (Initialize the converter).

- The display of the setting value automatically returns to that of the setting item in ten seconds. Unless a setting value is specified while it is displayed, it cannot be changed.
- The change is confirmed, and then a message of "rEtturn to FAcTory SETtinG" is displayed in turn.

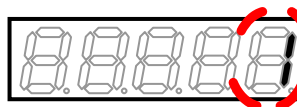

- Then, "SurE" blinks.
- Here, you can stop the initialization by pressing the [STOP/RESET] key.



12. Press the [SET] key.

- The converter mode name is displayed.



Indicating the converter mode "PWM sine wave mode"

13. Use the keys [↑] or [↓] to display a desired converter mode, and then press the [SET] key.

- The converter model is displayed.



"22" indicates the 200 V class.

14. Use the keys [↑] or [↓] to display a desired converter model, and then press the [SET] key.

· DC voltage is displayed.



15. Press the [→] key to blink required digits, press the keys [↑] or [↓] to change numbers to a value measured by the voltage meter or the tester, and then press the [SET] key.

- "init" is displayed for a few seconds, and then "End" is displayed. Now the initialization of the converter is completed.

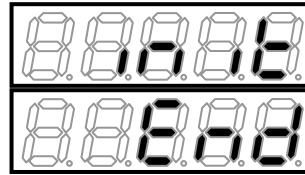

- About five seconds later, the converter series name is displayed.
- Then, contents similar to what are displayed at power-on are displayed. Refer to {4.2.2. What Are Displayed at Power-on}.
- Then, a monitor item is displayed for about one second, and its data is displayed.



16. Turn off the converter, and open the front cover.

17. Remove the installed DC voltage meter or tester.

18. Close the front cover.

Adjustment of various inputs

- After replacing the control board <VFC66R-Z>, be sure to adjust the AC voltage detection adjustment gain: n-05 according to {5.3.11. Area n}.
- Before using the analog input/output after replacement of the control board <VFC66R-Z>, be sure to adjust the analog input/output gain and offset.
- For how to adjust the analog input/output gain and offset, refer to {5.4.4. Analog Input (2) and (3) Gain and Offset Adjustment} through {5.4.5. Analog Output (2) and (3) Gain and Offset Adjustment}.

Chapter 9 Standard Specifications

9.1. Common Specifications

The table below lists the common specifications of the converter.

Control specifications	Operation mode	PWM sine wave mode/120-degree conduction mode		
	Converter method	Voltage type current control method (PWM sine wave mode)		
	Rated power supply voltage	200 V class	Three-phase three-wire 200 to 230 V ± 10 %	
		400 V class	Three-phase three-wire 380 to 460 V ± 10 %	
	Utility frequency	50/60 Hz ± 5 %		
	DC voltage range *1	200 V class	312 to 358 V	
		400 V class	600 to 716 V	
	Harmonic content (current)	PWM sine wave mode 5.0 % in total, 3.0 % each or less (rated operation)		
	Power factor	PWM sine wave mode 45 ° delay to 45 ° advance (settable range)		
Converter efficiency	96 % or more (rated output)			
Overload rated current	Unit rated AC current 150 % 60 sec			
Input/output signal	Operation signal	Start/stop, emergency stop (external failure), reset		
	Multifunction input	1 contact input		
	Contact output	Operation, protection, inverter operation enable, MC ON		
	Analog voltage output	AC current, AC voltage, AC power, etc. (using an option)		
Input/output with <I066-Z> option used	6 contact inputs : External failure signal, external traceback trigger, emergency stop (Normally closed) 2 open collector signals : During operation, during power failure, integrated power pulse, load pre-alarm 2 analog inputs 2 analog outputs			
One-point traceback	Data of six points, such as the history of last five protection operations and AC current/AC voltage/DC voltage at protection operation, are stored.			
Console monitor	DC voltage, AC current, AC voltage, AC frequency, AC power, overload counter, input/output terminal check, protection history display, etc.			
Protection function	Blown fuse, AC overcurrent, AC overload, DC part overvoltage, lowvoltage, unit overheat, IGBT protection operation, optional board error, startup stall, external failure, mode error, communication abnormality, etc.			
Unit protective structure	IP00 (JIS C 0920) : Open-type structure			
Environmental condition	Operating temperature: 0 to 50 °C Humidity: 20 to 90 %RH (no condensation) Altitude: 1000 m or less Atmosphere: No plasticizer such as corrosive gas, metallic powder, oil, halogen, and DOP should be contained. Vibration: 5.9 m/s ² (0.6 G or less, 10 to 55 Hz). Comply with JIS C60068-2-6. Under an environment not exceeding the overvoltage category III or the pollution degree 2 defined by IEC60664-1.			

*1: Cannot be lower than a value obtained by "power supply voltage x 1.56"

9.2. List of Models

■ 200 V class

Converter model	7522	9022
Unit rated AC current [A]	280	340
System voltage [V]	Three-phase three-wire 200 to 230 V ($\pm 10\%$) 50/60 Hz $\pm 5\%$	
Cooling method	Forcible cooling	
Weight [kg]	69	95

Parallel model

Converter model	15022	18022
Unit rated AC current [A]	560	680
System voltage [V]	Three-phase three-wire 200 to 230 V ($\pm 10\%$) 50/60 Hz $\pm 5\%$	
Single unit capacity and combined units	VF66R-7522 2 units in parallel	VF66R-9022 2 units in parallel
Cooling method	Forcible cooling	
Weight [kg]	69 × 2	95 × 2

■ 400 V class

Converter model	7544	11044
Unit rated AC current [A]	146	210
System voltage [V]	Three-phase three-wire 380 to 460V ($\pm 10\%$) 50/60 Hz $\pm 5\%$	
Cooling method	Forcible cooling	
Weight [kg]	58	76

Converter model	16044	20044	25044	31544
Unit rated AC current [A]	300	370	460	600
System voltage [V]	Three-phase three-wire 380 to 460V ($\pm 10\%$) 50/60 Hz $\pm 5\%$			
Cooling method	Forcible cooling			
Weight [kg]	92	149	156	220

Parallel model

Converter model	40044	50044	60044	75044	100044
Unit rated AC current [A]	740	920	1110	1380	1840
System voltage [V]	Three-phase three-wire 380 to 460V ($\pm 10\%$) 50/60 Hz $\pm 5\%$				
Single unit capacity and combined units	VF66R-20044 2 units in parallel	VF66R-25044 2 units in parallel	VF66R-20044 3 units in parallel	VF66R-25044 3 units in parallel	VF66R-25044 4 units in parallel
Cooling method	Forcible cooling				
Weight [kg]	149 × 2	156 × 2	149 × 3	156 × 3	156 × 4

Chapter 10 Outline Drawing of Converter

10.1. Standard Type

For the outline, the standard type is divided into a small type and large type depending on the model.

■ Small type

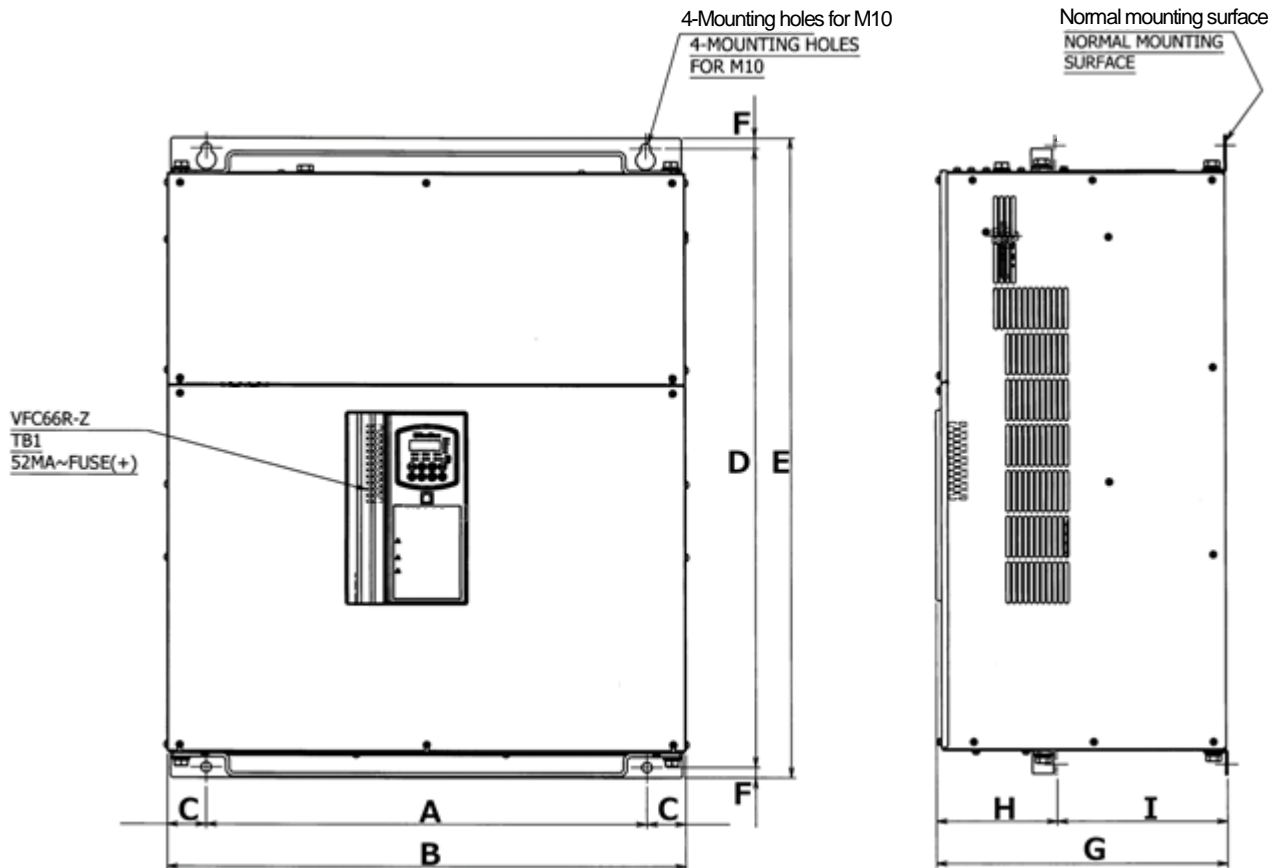

Converter model		Dimension (Unit: mm)								
200V class	400V class	A	B	C	D	E	F	G	H	I
7522	7544	410	500	45	695	720	12.5	350	145	205
9022	-	530	623	46.5	745	770	12.5	350	145	205
-	11044	530	623	46.5	745	770	12.5	350	145	205
-	16044	410	503	46.5	975	1000	12.5	350	145	205

※ For weight of the converter, refer to {9.2 List of Models}.

■ Large type

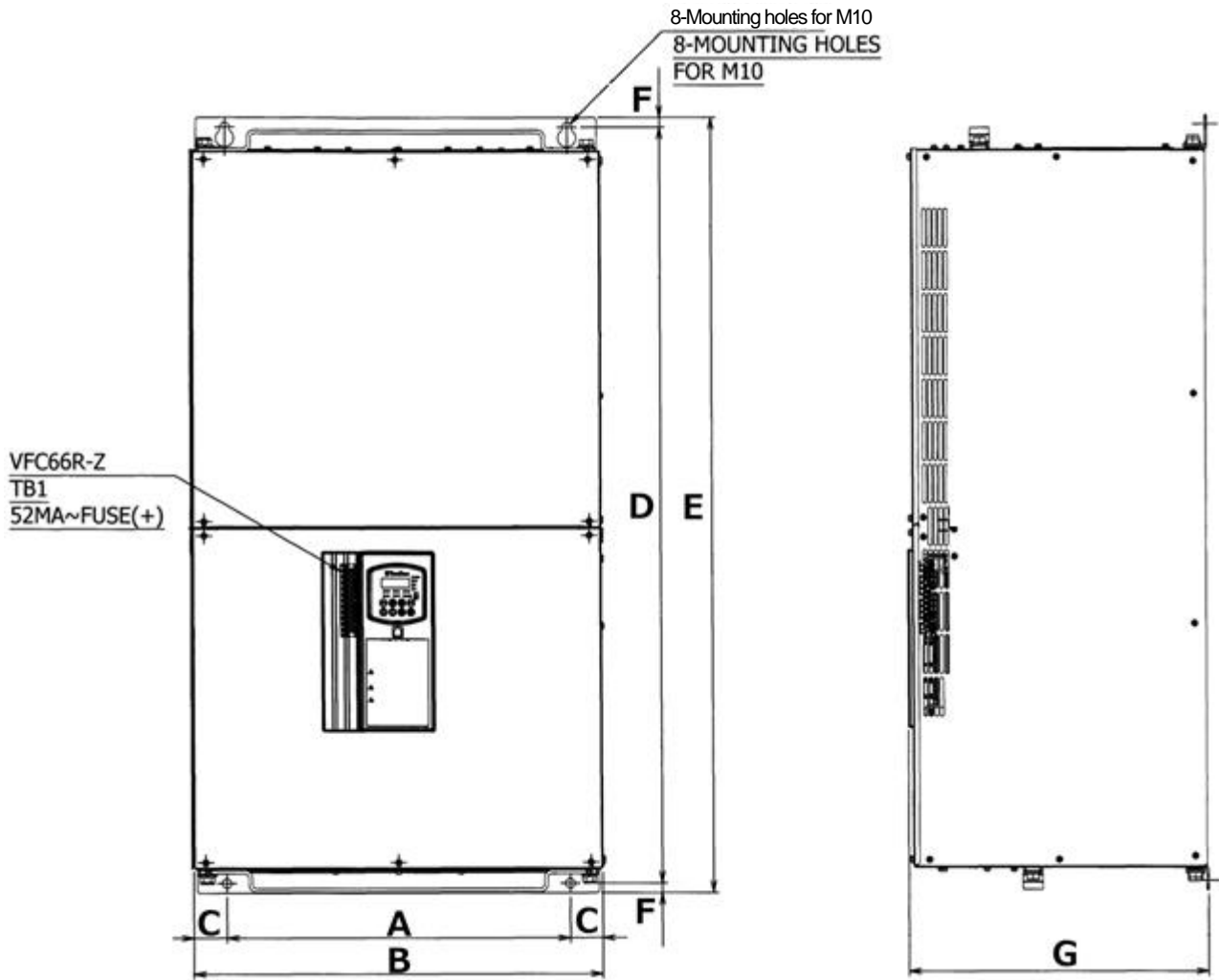

Converter model	Dimension (Unit: mm)						
	A	B	C	D	E	F	G
400V class							
20044	445	525	40	975	1000	12.5	386
25044	445	525	40	975	1000	12.5	386
31544	520	660	70	1100	1130	15	500

※ For weight of the converter, refer to {9.2 List of Models}.

10.2. Non-standard Type (Heat Generation Part Protruded Outside)

The heat generation part of the non-standard type converter is protruded outside from the control panel and others. Its installation requires a through hole.

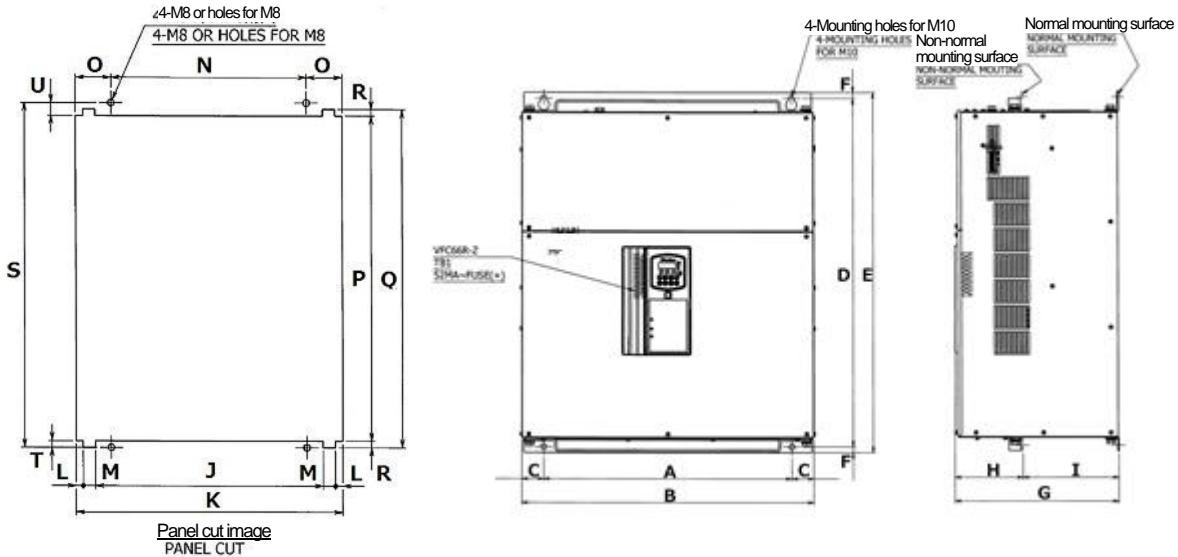

Converter model		Dimension (Unit: mm)								
200V class	400V class	A	B	C	D	E	F	G	H	I
7522	7544	410	500	45	695	720	12.5	350	145	205
9022	—	530	623	46.5	745	770	12.5	305	145	205
—	11044	530	623	46.5	745	770	12.5	305	145	205
—	16044	410	503	46.5	975	1000	12.5	350	145	205

The tables below list the dimensions of the through hole.

Converter model		Dimension (Unit: mm)								
200V class	400V class	J	K	L	M	N	O	P	Q	R
7522	7544	—	515	—	—	410	52.5	658	—	—
9022	—	—	635	—	—	530	52.5	708	—	—
—	11044	—	635	—	—	530	52.5	708	—	—
—	16044	—	515	—	—	410	52.5	940	—	—

Converter model		Dimension (Unit: mm)		
200V class	400V class	S	T	U
7522	7544	695	11	26
9022	—	745	11	26
—	11044	745	11	26
—	16044	975	11	24

※ For weight of the converter, refer to {9.2 List of Models}.

Chapter 11 VF64R Parameter Compatibility Chart

The parameter compatibility chart shows the compatibility of parameters with the old series VF64R. To replace with VF64R, set the parameters with reference to the parameter compatibility chart.

11.1. Basic Setting Area

Display		Contents
VF64R	VF66R	
0. VrEF	0. VrEF	DC voltage command
1. PHi	1. PHi	Power-factor angle
2. FrEq	2. FrEq	Power supply frequency

11.2. Area A (filter constant setting area)

Display		Contents
VF64R	VF66R	
A-00	A-00	AC reactor constant
A-01	A-01	Capacitance of filter capacitor
A-02	n-02	Carrier frequency

11.3. Area b (operation command related setting area)

Display		Contents
VF64R	VF66R	
DIPSW1-1	b-00	Setting data rewrite protection
b-00	b-02	Super-block function usage selection: VF64R/ PLCH function usage: VF66R
b-01	b-01	Sequence function selection: VF64R/ PLCL function usage: VF66R
b-02	b-03	Operation command source selection
b-03	b-04	DC voltage command source selection
b-04	b-05	Active current command source selection
b-05	b-06	Reactive current command source selection
b-06	b-07	Selection of restart after instantaneous power interruption

11.4. Area c (multifunction input/output related setting area)

Display		Contents
VF64R	VF66R	
c-00	c-00	Multifunction input source selection
c-01	c-01	Multifunction input terminal (1) [MI1] function selection: VF64R/ (6) [MI6] function selection: VF66R
c-02	c-02	Multifunction input terminal (2) [MI2] function selection: VF64R/ (7) [MI7] function selection: VF66R
c-03	c-03	Multifunction input terminal (3) [MI3] function selection: VF64R/ (8) [MI8] function selection: VF66R
c-04	c-04	Multifunction input terminal (4) [MI4] function selection: VF64R/ (9) [MI9] function selection: VF66R
c-05	c-05	Multifunction input terminal (5) [MI5] function selection: VF64R/ (10) [MI10] function selection: VF66R
c-06	c-06	Multifunction input terminal (6) [MI6] function selection: VF64R/ (11) [MI11] function selection: VF66R
c-07	-	Multifunction output terminal (1) [MO1] function selection: VF64R
c-08	-	Multifunction output terminal (2) [MO2] function selection: VF64R
c-09	c-07	Multifunction output terminal (3) [MO3] function selection
c-10	c-08	Multifunction output terminal (4) [MO4] function selection
c-11	c-09	Integrated power setting rate
c-12	c-10	Output pulse width upon arrival of integrated power setting
c-13	c-11	Overload pre-alarm operation level setting
c-14	c-12	MI1 input terminal function selection

11.5. Area E (control gain related setting area)

Display		Contents
VF64R	VF66R	
E-00	E-00	Current control proportional gain
E-01	E-01	Current control differential gain
E-02	E-02	Current control integral gain
E-03	E-03	DC voltage control basic proportional gain
E-04	E-04	DC voltage control maximum proportional gain
E-05	E-05	DC voltage control variable ramp rate
E-06	E-06	DC voltage control variable start voltage
E-07	E-07	DC voltage control integral gain
E-08	E-08	Unused
E-09	E-09	Unused
E-10	E-10	Active current command upper limit
E-11	E-11	Active current command lower limit
E-12	E-12	Reactive current command upper limit
E-13	E-13	Reactive current command lower limit
E-14	E-14	PLL proportional gain

11.6. Area F (protection function/traceback setting area)

Display		Contents
VF64R	VF66R	
F-00	F-00	Overload protection setting
F-01	F-01	FCL level setting
F-02	F-08	Traceback_pitch
F-03	F-09	Traceback_trigger_point
F-04 through 15	F-10 through 21	Traceback CH1 through 12 selection

11.7. Area G (setting area for analog input and output)

Display		Contents
VF64R	VF66R	
G-00	L-9, 11	Analog input positive side adjustment gain: VF64R/ analog input (2), (3) gain: VF66R
G-01	L-9, 11	Analog input negative side adjustment gain: VF64R/ analog input (2), (3) gain: VF66R
G-02	L-07	Analog input characteristics selection: VF64R/ analog input (2), (3) characteristics selection: VF66R
G-03	-	Analog input zero limit: VF64R
G-04	L-10, 12	Analog input offset adjustment amount: VF64R/ analog input (2) offset: VF66R
G-05	L-01	Analog output selection: VF64R/ analog output (2) selection: VF66R
G-06	L-03	Analog output adjustment gain: VF64R/ analog output (2) gain: VF66R
G-07	L-04	Analog output adjustment offset: VF64R/ analog output (2) offset: VF66R
G-08	L-02	Analog output 2 selection: VF64R/ analog output (3) selection: VF66R
G-09	L-05	Analog output 2 adjustment gain: VF64R/ analog output (3) gain: VF66R
G-10	L-06	Analog output 2 adjustment offset: VF64R/ analog output (3) offset: VF66R
G-11	-	Insulated analog input adjustment gain: VF64R
G-12	-	Insulated analog input offset adjustment amount: VF64R

Analog input/output

- The analog input/output terminal configuration varies by the product series. Set the parameters with reference to {5.3.3. Area b} and {5.3.10. Area L}.

11.8. Area J (communication option setting area)

Options vary by the product series.

Set the parameters with reference to {5.3.9. Area J}.

11.9. Area o (special adjustment area)

Display		Contents
VF64R	VF66R	
o-03	n-06	Special adjustment

11.10. Area P (special adjustment area)

Display		Contents
VF64R	VF66R	
P-000 through 259	P-000 through 259	Special adjustment (super-block related setting area)

11.11. Area S (converter capacity/DC voltage detection gain area)

Display		Contents
VF64R	VF66R	
S-00	L-00	Vdc detection gain
S-01	n-00	Converter control mode (read-out only)
S-02	n-01	Converter capacity/voltage class (read-out only)

Chapter 12 Attentions for Contacting Us

If you want to order a replacement for a failed part or have a technical question, let us or your supplier know the issues below.

- (1) Model and input voltage (V) of your converter
- (2) Serial number and software version No. of your converter
 - For the software version No., check a label attached to the control board <VFC66R-Z> as shown in the figure to the right.
- (4) Descriptions of a failure and a state when it occurs
- (5) Operating state, load state, ambient condition, date of purchase, operation condition
- (6) Distributor name, sales department name

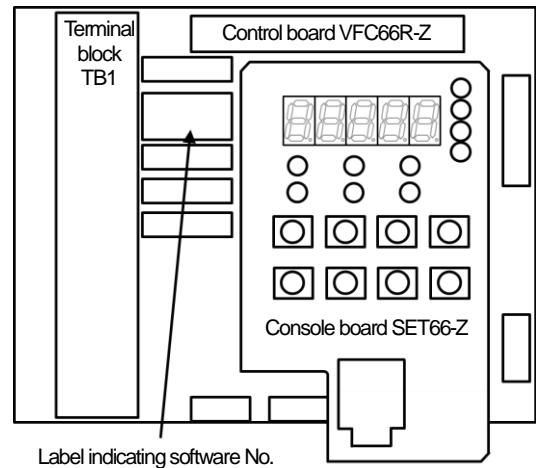

■ Attentions to distributors

When delivering this converter with your any product built in, consider that this manual can be distributed to end users.

Also, when changing our Initialized data for setting parameters of this converter, consider that the changed value would be delivered to end users.

Chapter 13 Industrial Product Warranty

13.1. No-charge warranty Period

The free of charge warranty period shall be "less than 1 year after installation in your company or your customers" or "less than 18 months after shipment from the factory or storage warehouse," whichever comes first.

In the case of repair, overhaul or other maintenance by Toyo Denki or a company designated by Toyo Denki, the warranty period for the parts concerned shall be for one year from the date of acceptance inspection.

13.2. Warranty Scope

13.2.1. Problem diagnosis

As a general rule, initial diagnosis in the event of product failure should be performed by your company. However, if you request initial problem diagnosis, it can be performed on your behalf by Toyo Denki or a member of our service network.

Please note that if Toyo Denki is not responsible for the cause of the failure, a fee will be charged for the initial diagnosis.

13.2.2. Repair

Repair, part replacement, and onsite repair shall be provided free of charge.

However, this shall not apply in the following cases:

- ① When the problem is a result of improper product handling, conditions, environment, usage method, etc., by you or your customer
- ② When the problem was caused by a system designed by you or your customer
- ③ When the problem was caused by deficiencies in a program created by you or your customer
- ④ When the problem originated in something other than the delivered product
- ⑤ When the problem was caused by modification performed without the prior approval of Toyo Denki
- ⑥ When the problem was caused by repair or modification performed by someone other than Toyo Denki or a company designated by Toyo Denki
- ⑦ When the problem was caused by a force majeure such as a natural disaster, fire, or accident.
- ⑧ Other cases where Toyo Denki is not responsible for the cause of the problem
- ⑨ The no-charge warranty period has expired

13.3. Disclaimers

Irrespective of whether the no-charge warranty period is in effect, this warranty shall not compensate you or your customer for any damages that are not the responsibility of Toyo Denki, or for any lost opportunity, lost profit, secondary damages, or accident due to the failure of the Toyo Denki product concerned.

Moreover, compensation shall not be provided relating to articles other than the Toyo Denki product concerned.

13.4. Repair period after product discontinuation

Once the product has gone out of production, Toyo Denki will continue to provide repair service for the product for a period of seven years.

However, please note that the procurement of electronic components for the product may become difficult during that time, and repair may not be possible.

13.5. Delivery Condition

In the case of standard products ordered without test operation and adjustment, delivery shall take place upon product arrival at your company, and Toyo Denki shall not be responsible for onsite test operation and adjustments.

All Rights

The copyright of this manual belongs to Toyo Denki. Duplicating all or part of contents of this manual without obtaining permission from the right holder is prohibited under the Copyright Act.

All rights of company names and product names described in this manual belong to their respective owners.

TOYODENKI SEIZO K.K.

<https://www.toyodenki.co.jp/en/>

HEAD OFFICE: Tokyo Tatemono Yaesu Bldg, 1-4-16 Yaesu, Chuo-ku,
Tokyo, Japan ZIP CODE 103-0028
TEL : +81-3-5202-8132 - 6
FAX : +81-3-5202-8150

In addition, the contents of this the "operating manual" may be changed without a preliminary announcement by specification change of a product etc. Please understand that it may differ from the contents of the "operating manual" enclosed by the model of purchase, and the contents of the "operating manual" posted on our homepage.

Please have a look from our homepage about the newest "operating manual".

TIM069 [E]_20230126